

2 - Loading table

CODE	DESCRIPTION
130410	STOP CONTACT F40 CN RED
130411	START CONTACT YELLOW
130413	GREEN PUSH BUTTON
130476	ROTATIVE EMERGENCY SWITCH
130477	CONTACT NC
170447	PINION Z=7 P60
190653	LOOSE WHEEL BUSH ENTRY BRACKET
191079	SPLASH PROTECTION ENTRY TABLE
260103	SCREW TE 6X12
260112	STAINLESS STEEL TE-SCREW 8X16
260113	STAINL.ST.TE SCREW 8X20 A2 UNI
260223	M5X12 MSH/HD SCREW SPECIAL S/S
260403	NUTS D.5
260404	STAINLESS STEEL NUTS D6 UNI 55
260406	NUT 8MA
260408	S/S NUTS D.12
260412	SELF-LOCKING NUT M6
260503	STAINL.STEEL FLAT WASHER D5 UN
260511	GROWER WASHER D.5
260512	ST/ST GROWER WASHER D6
260513	GROWER WASHER D8
260535	STAINL.ST WASHER 24X8,5X2
260538	WASHER 18X6X1,5 ST/ST
322285	SUPPORT
322719	PROFILE
322853	COVER FOR WHEEL
322981	DOOR INSPECTION NE
330201	ROD FOR BELT ADJUSTING "N"
332051	FILTER FOR ENTRY TABLE NG2
340627	ENTRY TEBLE NEXL
341833	SUPPORT
342091	IDLE SHIFT NG/LVP
351658	PANEL 600MM NE
351671	PANEL 600MM RIGHT NE
351692	PANEL WITH CONTROLS 300
351719	PANEL
351921	PANEL 300MM
381101	PLATE
440208	FOOT INSERT
440209	COMPLETE FOOT NE
441503	LOCKING
461139	PLATE
463137	SELF ADHESIVE SYMBOL
510511	SUPPORT FOR AXLE

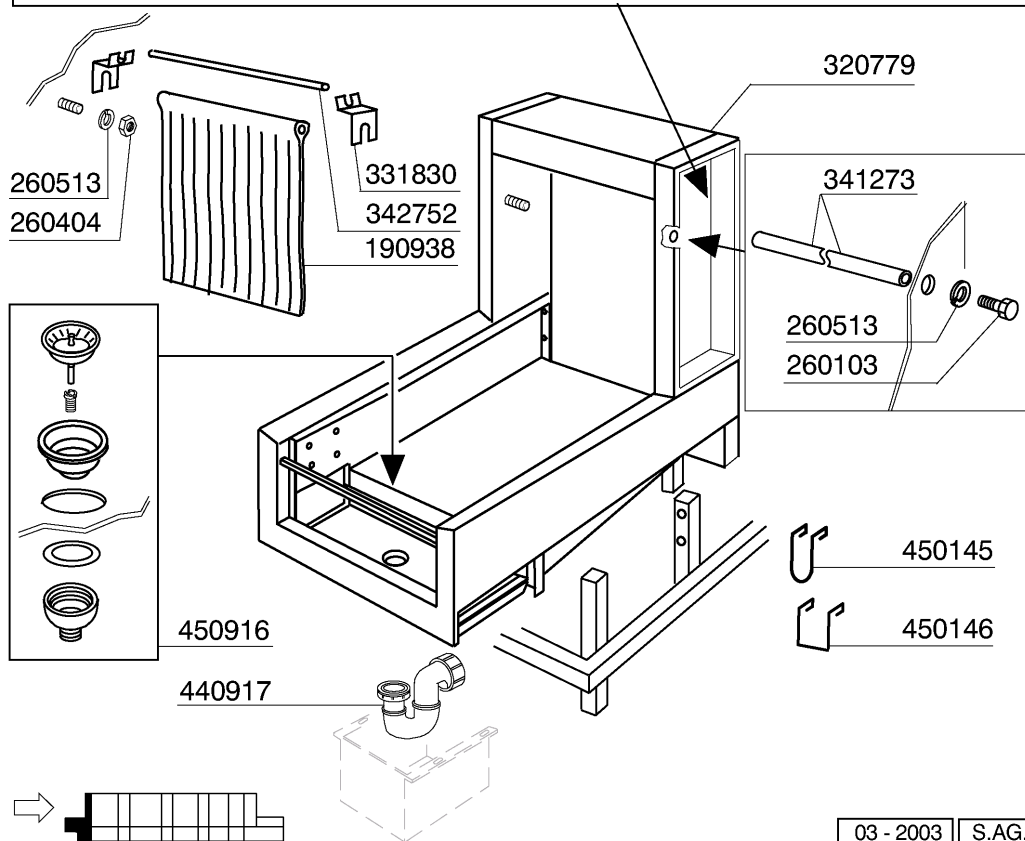
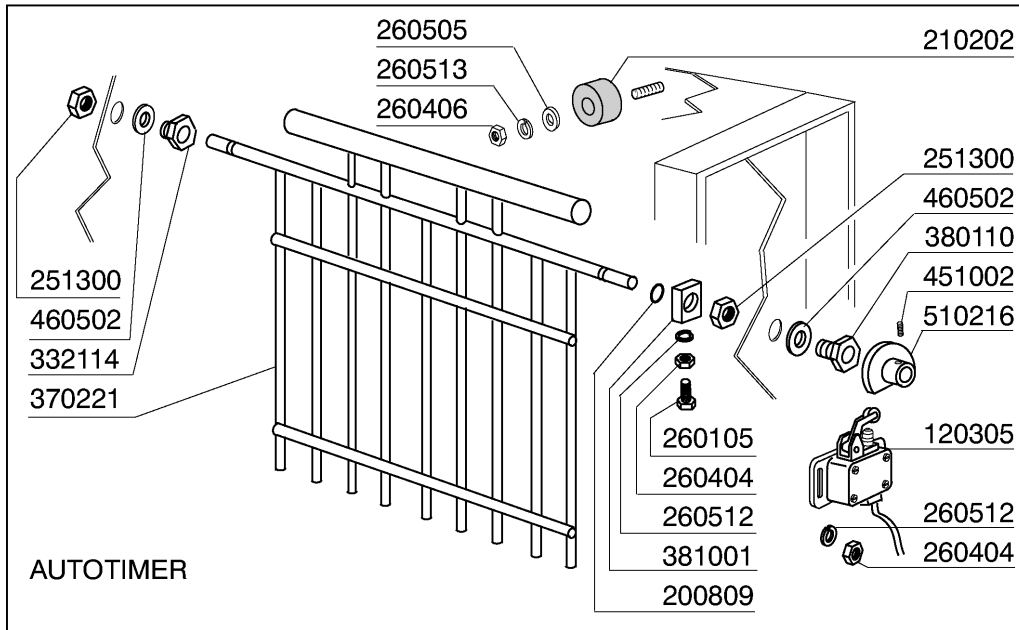

3 - Loading table

CODE	DESCRIPTION
120305	MICRO SWITCH WITH LEVER
190938	CURTAIN INLET NG
200809	OR GASKET 1,78X8,73X12,29
210202	RUBBER FOOT GLASSWASHER
251300	S/S LOCK NUT 1/2" AC-ACR
260103	SCREW TE 6X12
260105	SCREW TE 6X20
260404	STAINLESS STEEL NUTS D6 UNI 55
260406	NUT 8MA
260505	STAINL.STEEL FLAT WASHER D8
260512	ST/ST GROWER WASHER D6
260513	GROWER WASHER D8
320779	SPLASH HOOD NG2
331830	BRACKET FOR CURTAIN
332114	BUSH FOR ECONOMISER
341273	LEVER
342752	SHAFT FOR CURTAIN NG2
370221	RINSE GATE BTM UV
380110	BRASS BEARING D12 F.ECON.N
381001	LOCKING NUT FOR ECONOMIZER N
440917	ENTRY TABLE SIPHON
450145	SUPPORT
450146	SUPPORT
450916	THERMOMETER 1,5MT ØF/ØC
451002	COTTER PIN STAINL.ST. D2X12
460502	GASKET 30X21X2
510216	N RINSE GATE ECCENTRE

4 - 1st Wash Hood 900mm

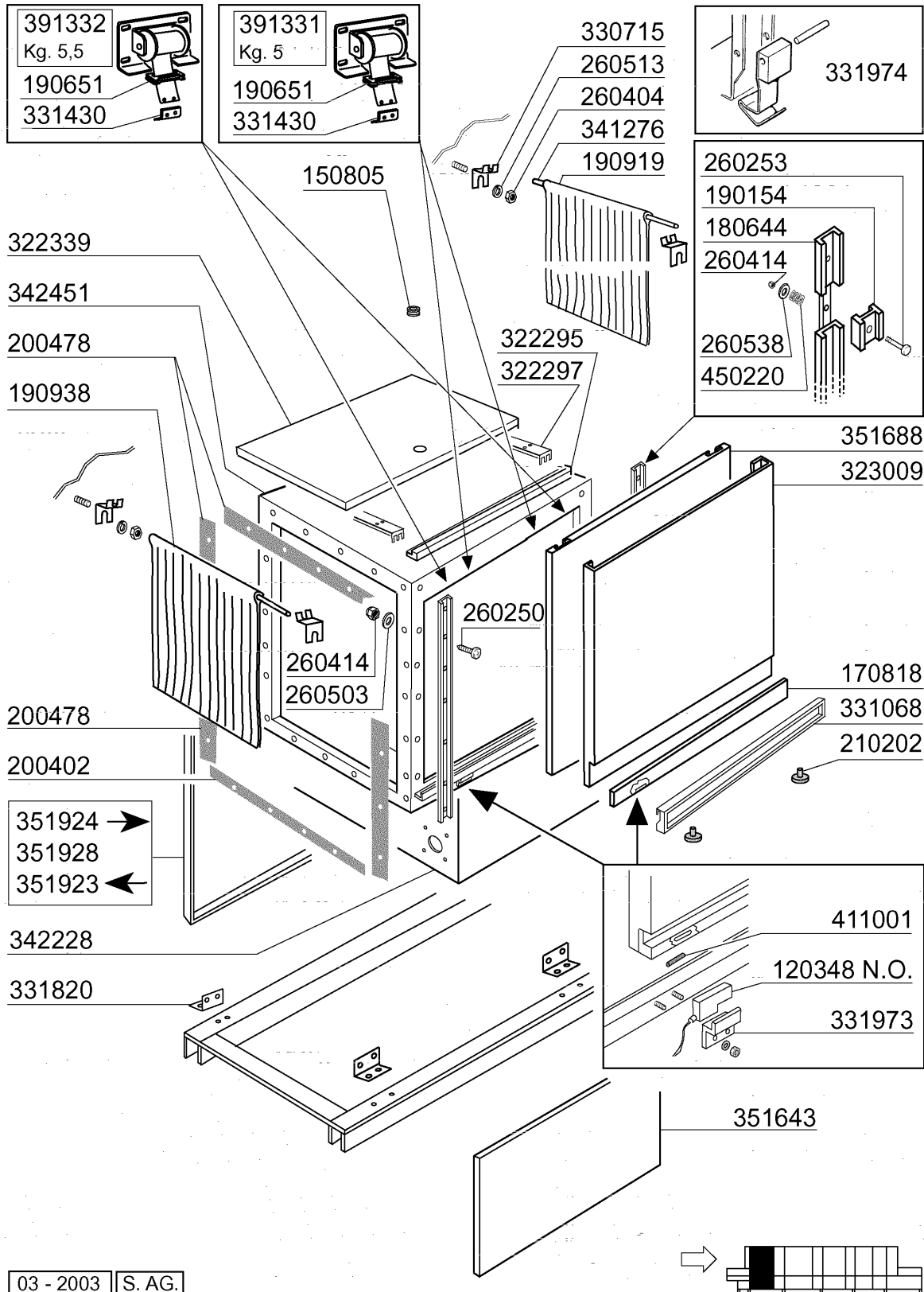

4 - 1st Wash Hood 900mm

CODE	DESCRIPTION
120348	MAGN.SWITCH (N.O.)
150805	CABLE HOLDER 18X22X1
170818	SUPPORT FOR HANDLE 900 NE
180644	NG DOOR RAIL WITH BRAKE
190154	BRAKE
190651	BUSH
190919	MIDDLE CURTAIN NG-910X680
190938	CURTAIN INLET NG
200402	SELF-ADHES.RUBB.SPONGE STRIPS
200478	SELF-ADHESIVE GASKET 65X4
210202	RUBBER FOOT GLASSWASHER
260250	SCREW TB 5X20
260253	SCREW 5X35
260404	STAINLESS STEEL NUTS D6 UNI 55
260414	SELF-LOCKING NUT M5
260503	STAINL.STEEL FLAT WASHER D5 UN
260513	GROWER WASHER D8
260538	WASHER 18X6X1,5 ST/ST
322295	SUPPORT
322297	SUPPORT
322339	COVER 90MM NG2
323009	DOOR 900MM NG2
330715	UPPER BRACKET CURTAIN SNL-SE
331068	DOOR HANDLE 900 NE02
331430	BRACKET FOR DOOR SPRING
331820	BRACKET
331973	DOOR MICRO SWITCH BRACKET
331974	SUPPORT FOR DOOR HOOK
341276	SPINDLE FOR CURTAIN NG
342228	WASH TANK 900 XL
342451	HOOD 900MM NG2
351643	PANEL 900MM NE
351688	INSULATED PANEL
351923	BACK PANEL 900MM RIGHT
351924	BACK PANEL 900MM LEFT
351928	PANEL
391331	SPRING ASSEMBLY KG. 5 MM 40
391332	DOOR SPRING 5,5 KG - 40MM
411001	PERMANENT MAGNET 8X40
450220	SPRING

5 - 1st Wash upper column 900mm

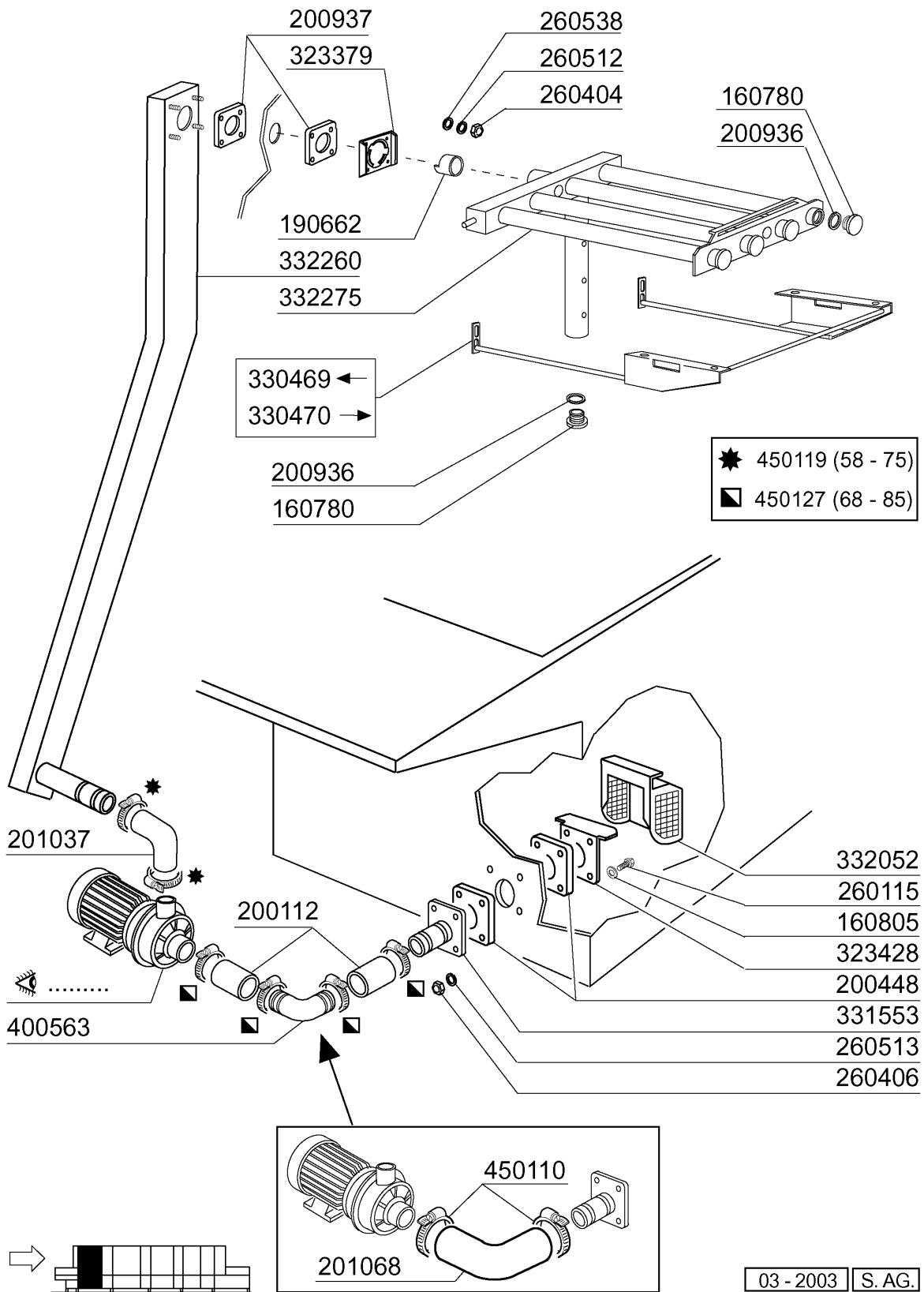

5 - 1st Wash upper column 900mm

CODE	DESCRIPTION
160780	PLUG FOR WASH ARM
160805	GASKET D.8
190662	BUSH
200112	RUBBER TUBE 75X83
200448	GASKET 100X100X3 HOLE D.76
200936	GASKET
200937	GASKET F.LOWER WASH ARM
201037	OUTLET HOSE
201068	SUCTION HOSE
260115	STAIN.ST.TE SCREW 8X20 A2 UNI
260404	STAINLESS STEEL NUTS D6 UNI 55
260406	NUT 8MA
260512	ST/ST GROWER WASHER D6
260513	GROWER WASHER D8
260538	WASHER 18X6X1,5 ST/ST
323379	HOOK FOR WASH MANIFOLD
323428	FILTER BRACKET
330469	RIGHT SUPPORT FOR UPPER WASH A
330470	LEFT SUPPORT UPPER WASH ARM
331553	INLET ELBOW FOR NG-GL WASH PUM
332052	SUCTION FILTER NG2
332260	UPPER WASH COLUMN NG2
332275	UPPER WASH SYSTEM NG2
400563	DELIVERY ELBOW G65/115 ‡ STAIN
450110	HOSE CLAMP 77-95
450119	CLAMP FE ZN. 58-75 H=12,2
450127	CLAMP FE ZN. 68-85 H=12,2

6 - 1st Wash lower column 900mm

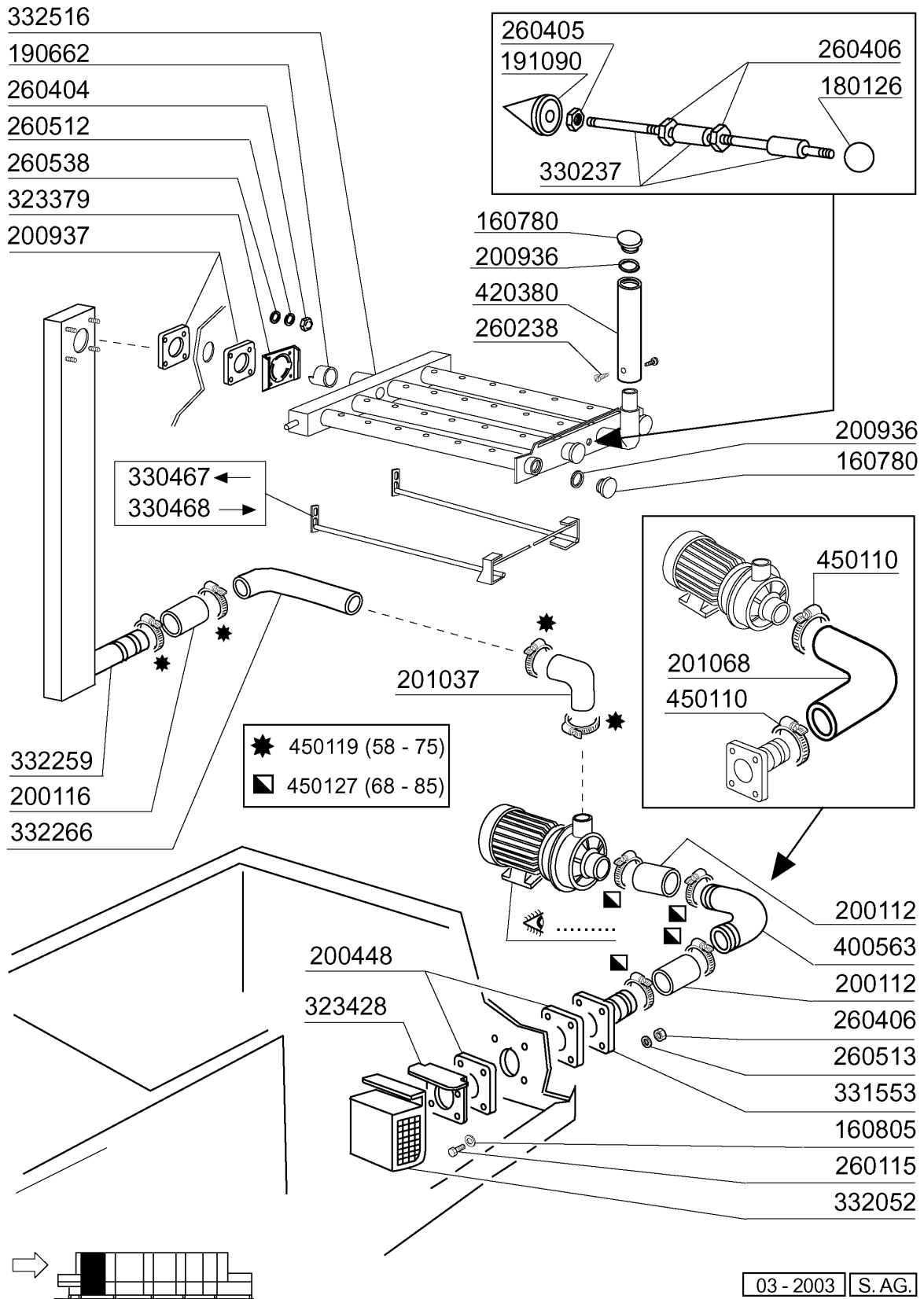

6 - 1st Wash lower column 900mm

CODE	DESCRIPTION
160780	PLUG FOR WASH ARM
160805	GASKET D.8
180126	HANDLE F.OVERFLOW PIPE SNL
190662	BUSH
191090	REDUCER LOWER WASH ARM NG2
200112	RUBBER TUBE 75X83
200116	RUBBER HOSE 60X70
200448	GASKET 100X100X3 HOLE D.76
200936	GASKET
200937	GASKET F.LOWER WASH ARM
201037	OUTLET HOSE
201068	SUCTION HOSE
260115	STAIN.ST.TE SCREW 8X20 A2 UNI
260238	M4 X 10 MUSH/HD SCREW
260404	STAINLESS STEEL NUTS D6 UNI 55
260405	NUT D.8
260406	NUT 8MA
260512	ST/ST GROWER WASHER D6
260513	GROWER WASHER D8
260538	WASHER 18X6X1,5 ST/ST
323379	HOOK FOR WASH MANIFOLD
323428	FILTER BRACKET
330237	TIE ROD FOR WASH ARM NG2
330467	RIGHT SUPPORT FOR LOWER WASH A
330468	LEFT SUPPORT FOR LOWER WASH AR
331553	INLET ELBOW FOR NG-GL WASH PUM
332052	SUCTION FILTER NG2
332259	LOWER WASH COLUMN NG2
332266	OUTLET HOSE NG2
332516	LOWER WASH SYSTEM NG2
400563	DELIVERY ELBOW G65/115 ‡ STAIN
420380	SIDE WASH ARM
450110	HOSE CLAMP 77-95
450119	CLAMP FE ZN. 58-75 H=12,2
450127	CLAMP FE ZN. 68-85 H=12,2

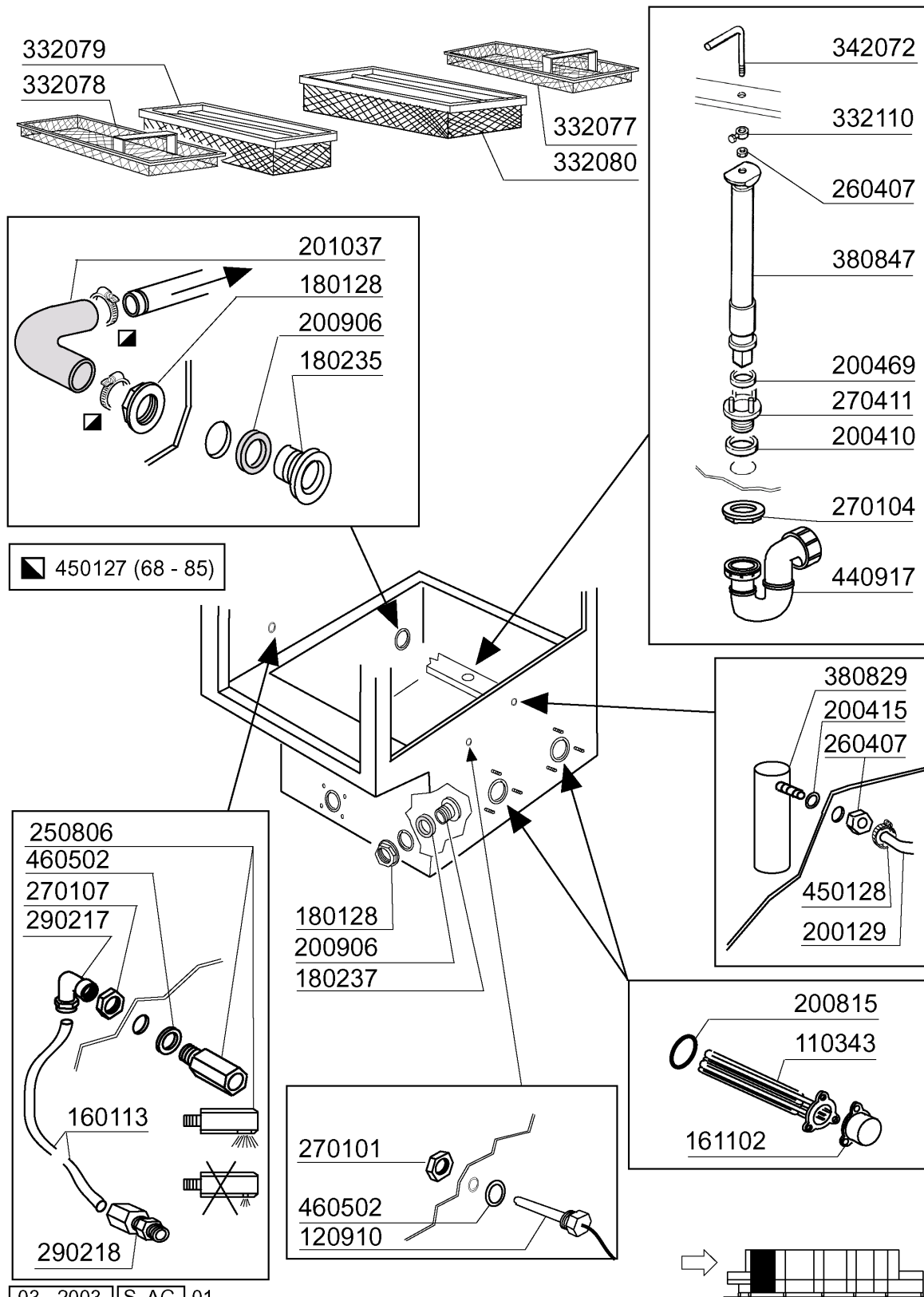

7 - 1st Wash Tank 900mm

CODE	DESCRIPTION
110343	HEAT.ELEM. 8000W 220/380V
120910	ELECTRONIC TOUCH PAD CONTROLS
160113	TUBE IN POL. RETIC. 12 EST
161102	ELEMENT COVER MOPL.
180128	RING NUT 65,4 C140 C85
180235	PUMP SUCTION C85-140
180237	PLUG D.65
200129	HOSE 5X11 FOR PRESSURE SWITCH
200410	DRAIN OUTL.WASH.1 1/2"65X47X2
200415	AIR TRAP GASKET -F2 18,5X10X3
200469	STAND PIPE O RING 45X35,5X7
200815	O-RING F. HEAT.ELEM.
200906	GASKET D.92X66X2
201037	OUTLET HOSE
250806	TANK FILL HOSE CLAMP - AC/ACR
260407	STAINLESS STEEL NUTS D10 UNI 5
270101	HEXAGON LOCK NUT 1/2"
270104	LOCK NUT 1" 1/2
270107	BRASS LOCK NUT 3/8" FL803
270411	DRAIN OUTLET F. PREWASH/ECOR.
290217	HOSE CLAMP ELBOW 12X3/8" TYPE
290218	NIPPLE 12X1/2"
332077	RIGHT FLAT FILTER NG2
332078	LEFT FLAT FILTER NG2
332079	SMALL FILTER DRAWER NG2
332080	FILTER DRAWER NG2
332110	CLAMPING PIECES
342072	PREWASH ROD NE02
380829	ST/ST AIR CHAMBER FOR NG-NE
380847	OVERFLOW PIPE
440917	ENTRY TABLE SIPHON
450127	CLAMP FE ZN. 68-85 H=12,2
450128	CLAMP
460502	GASKET 30X21X2

E 3

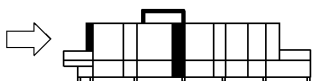
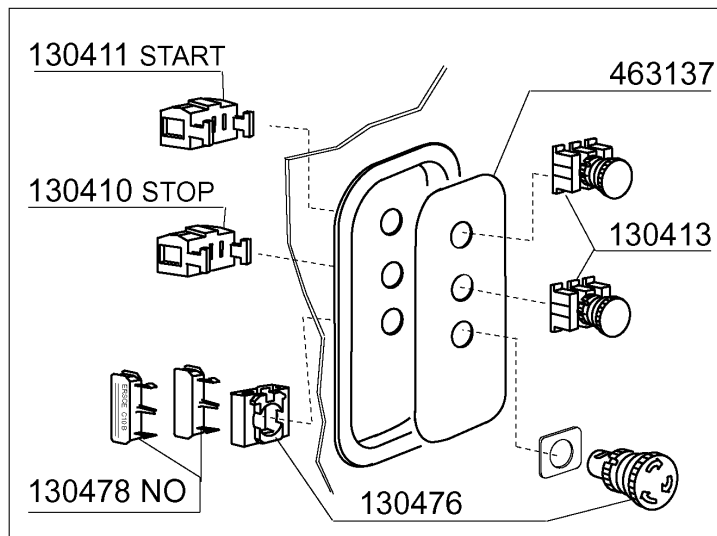
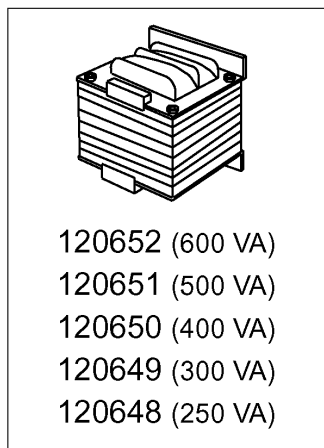
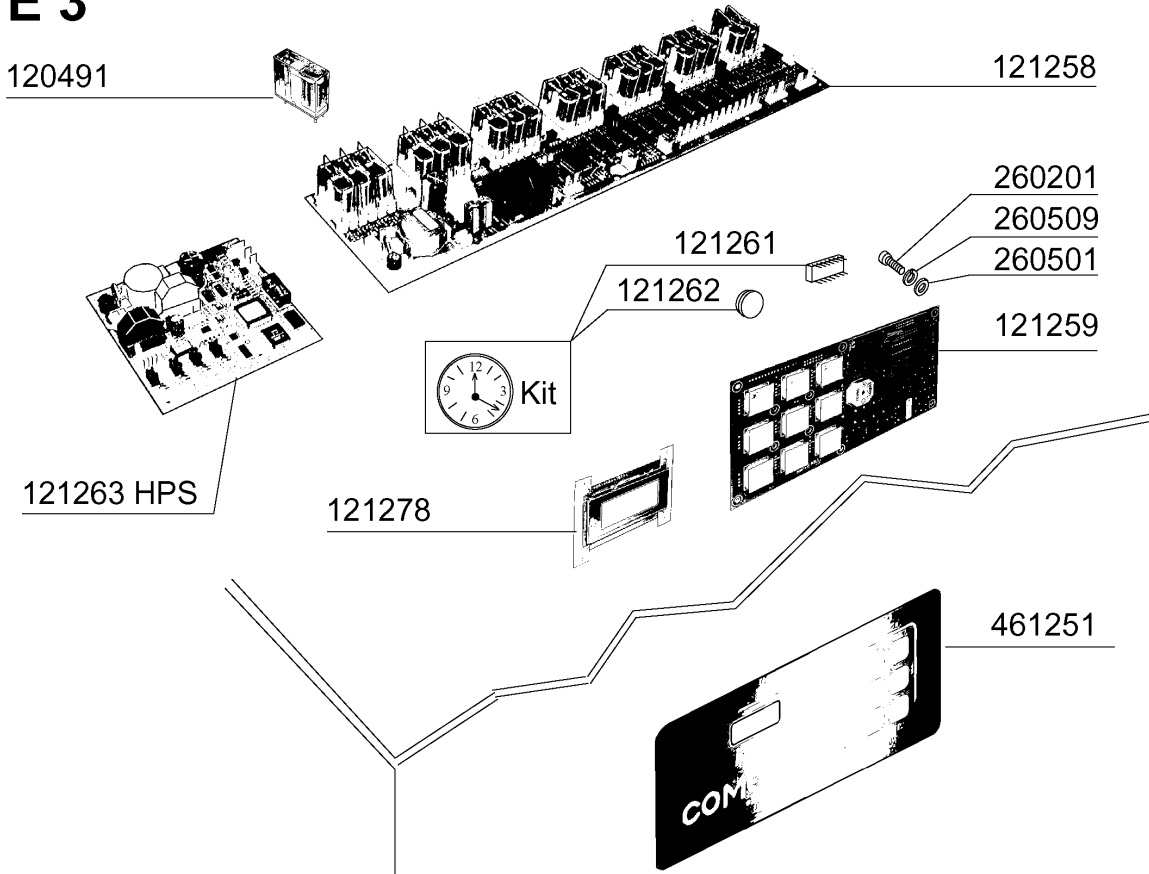

03 - 2003 S. AG.

8 - ELECTRONIC 3 components

CODE	DESCRIPTION
120491	RELAIS 10A 9V
120648	TRANSFORMER 250VA225-240-380-4
120649	TRANSFORMER 300VA225-240-380-4
120650	TRANSFORMER 400VA225-240-380-4
120651	TRANSFORMER 500VA225-240-380-4
120652	TRANSFORMER 600VA225/415-24/24
121258	MAIN PCB E3
121259	KEYBOARD PCB
121261	WATCH
121262	LITHIUM BATTERY 3V.CR2450N
121263	HPS BOARD
121278	DISPLAY LCD 4X16
130410	STOP CONTACT F40 CN RED
130411	START CONTACT YELLOW
130413	GREEN PUSH BUTTON
130476	ROTATIVE EMERGENCY SWITCH
130478	CONTACT N.O.
260201	SCREW TCP 3X10
260501	STAINL.STEEL FLAT WASHER D3 UN
260509	GROWER WASHER D.3
461251	PLATE E3 (NEUTRAL)
463137	SELF ADHESIVE SYMBOL

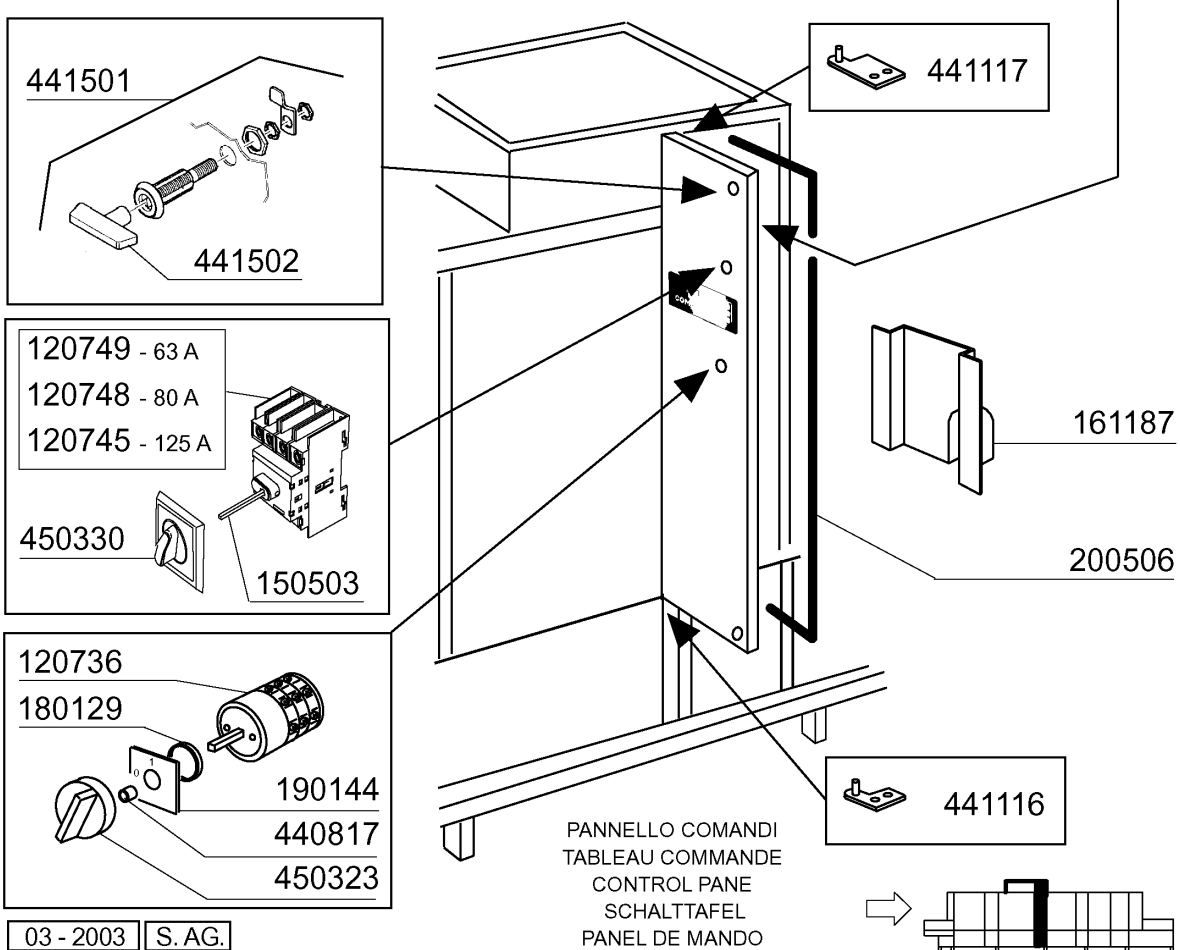
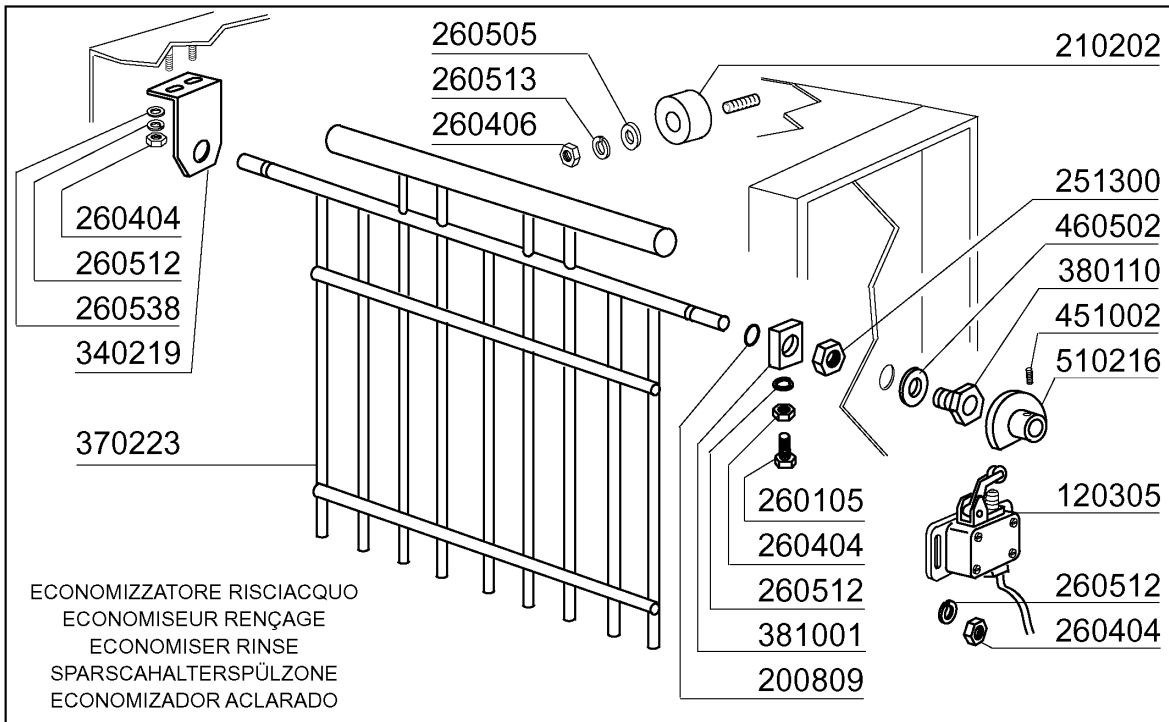

9 - Control panel / Economiser rinse

CODE	DESCRIPTION
120305	MICRO SWITCH WITH LEVER
120736	4 POLE MAIN SWITCH 25A 500V
120745	MAIN SWITCH 4 POLE 125A
120748	MAINSWITCH 80A 4P
120749	MAINSWITCH 63A 4P
150503	EXTENTION FOR MAIN SWITCH
161187	COVER FOR PCB
180129	NUT FOR MAIN SWITCH SUPPORT
190144	MAIN SWITCH HOLDER
200506	GASKET GUISNAP UNIVERS.861
200809	OR GASKET 1,78X8,73X12,29
210202	RUBBER FOOT GLASSWASHER
251300	S/S LOCK NUT 1/2" AC-ACR
260105	SCREW TE 6X20
260404	STAINLESS STEEL NUTS D6 UNI 55
260406	NUT 8MA
260505	STAINL.STEEL FLAT WASHER D8
260512	ST/ST GROWER WASHER D6
260513	GROWER WASHER D8
260538	WASHER 18X6X1,5 ST/ST
340219	SUPPORT FOR ECONOMIZER N
370223	RINSE GATE NG2
380110	BRASS BEARING D12 F.ECON.N
381001	LOCKING NUT FOR ECONOMIZER N
440817	SNAP RING LSCB/1853/17/00
441116	LOWER DOOR HINGE 400 NG2
441117	UPPER DOOR HINGE NG2
441501	LOCK
441502	KEY FOR CONTROL PANEL
450323	KNOB FOR BC-BR-C95-C155
450330	KNOB FOR MAIN SWITCH
451002	COTTER PIN STAINL.ST. D2X12
460502	GASKET 30X21X2
510216	N RINSE GATE ECCENTRE

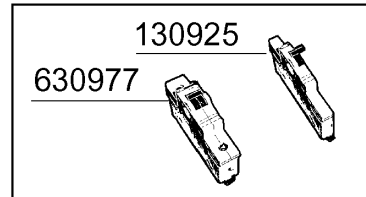
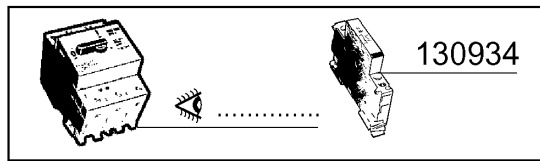

	QF 18 - S 251 C.....	4 Amp.	121040
	QF 16 - S 251 C.....	4 Amp.	121040
		10 Amp.	121043
		13 Amp.	121044
		16 Amp.	121045
	20 Amp.	121046	
	QF 17 - S 252 K.....	1 Amp.	121047
		2 Amp.	121048
		3 Amp.	121049
		4 Amp.	121050
		6 Amp.	121051

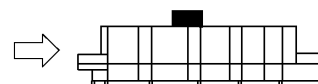
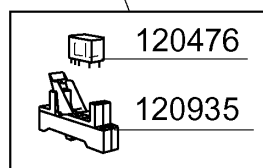
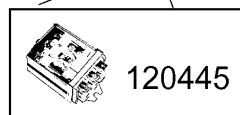
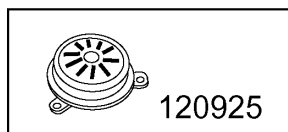
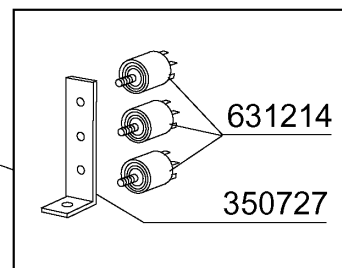
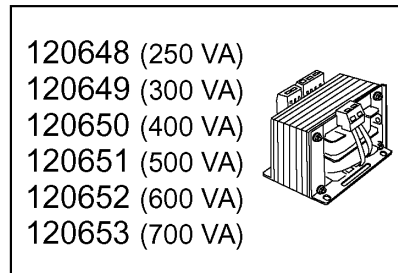
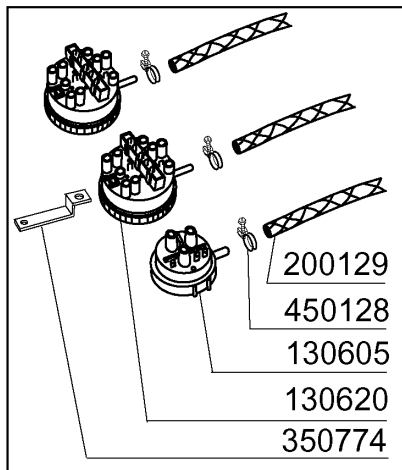
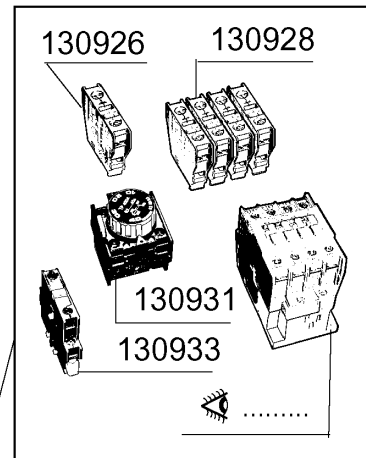

04 - 2003 S. AG.

10 - Control Box

CODE	DESCRIPTION
120445	AUXILIARY RELAY S.B2/3 24V
120476	RELAY 16A 24V
120648	TRANSFORMER 250VA225-240-380-4
120649	TRANSFORMER 300VA225-240-380-4
120650	TRANSFORMER 400VA225-240-380-4
120651	TRANSFORMER 500VA225-240-380-4
120652	TRANSFORMER 600VA225/415-24/24
120653	TRANSFORMER 700VA 240-415/24
120925	ACUSTIC SIGNAL
120935	SUPPORT
121040	MAGNETOT. SWITCH S251 C4
121043	MAGNETOT. SWITCH S251 C10
121044	OVERLOAD RELAY S251 C13
121045	OVERLOAD RELAY S251 C16
121046	OVERLOAD RELAY S251 C20
121047	MAGNETOT. SWITCH S252 K1
121048	OVERLOAD RELAY S252 K2
121049	OVERLOAD RELAY S252 K3
121050	OVERLOAD RELAY S252 K4
121051	OVERLOAD RELAY S252 K6
121276	INVERTER 0,25KW
130605	PRESSURE SWITCH 50-30 1 LEVEL
130620	PRESSURE SWITCH 3 LEVEL 50-30/
130925	CONTACT FOR CIRCUIT BREAKER
130926	CONTACT ABB 1NO
130928	CONTACT ABB 4NO
130931	CONTACT ABB 1NO/1NC 30"
130933	SUPPL. CONTACT NO/NC ABB
130934	AUXILIARY CONTACTS 1NO+1NC
200129	HOSE 5X11 FOR PRESSURE SWITCH
350727	BRACKET
350774	BRACKET
450128	CLAMP
630977	COIL FOR CIRCUIT BREAKER 24V
631214	ANTI-NOISE FILTER 4011135007 3

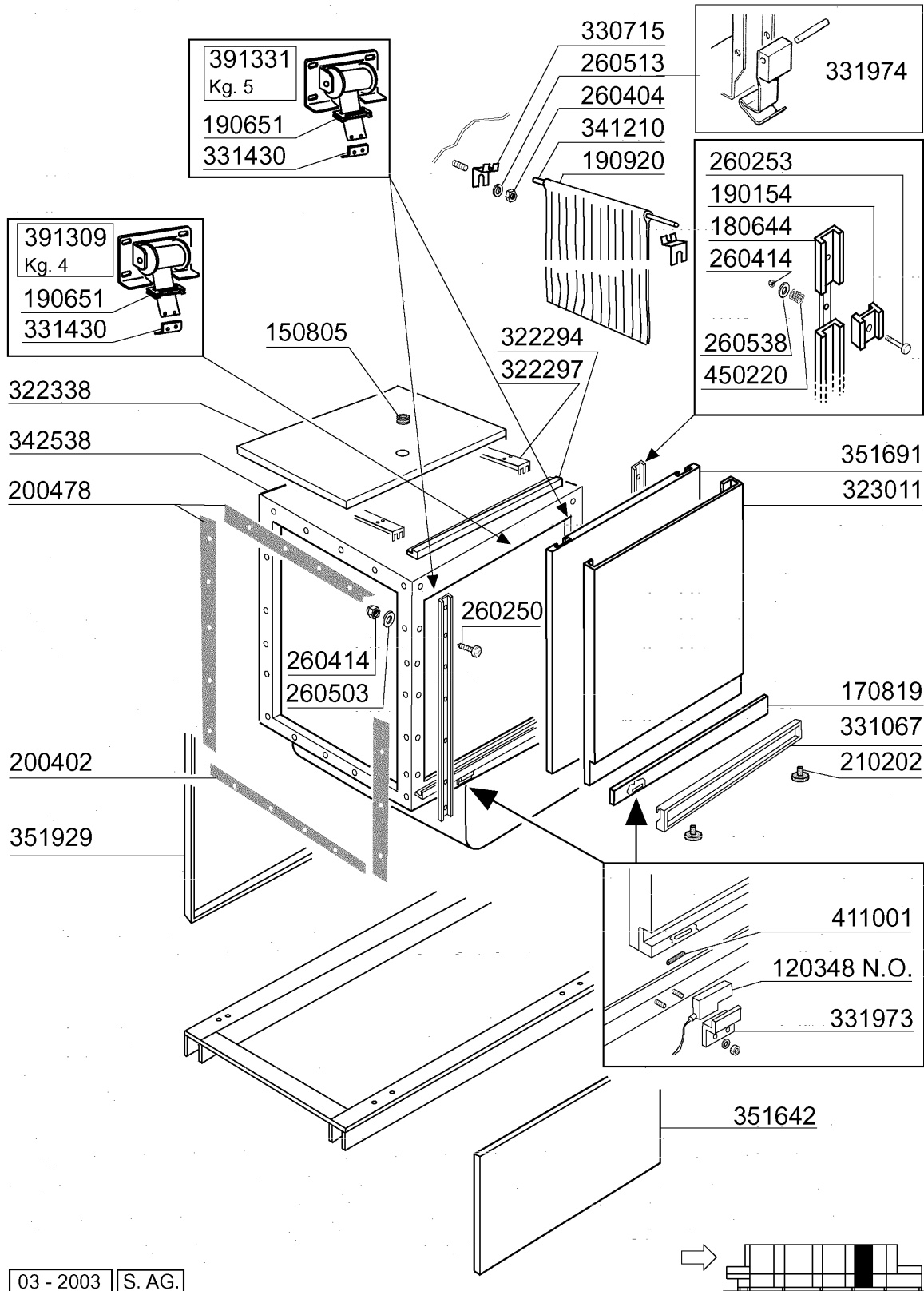

11 - Hood Ecorinse 600mm

CODE	DESCRIPTION
120348	MAGN.SWITCH (N.O.)
150805	CABLE HOLDER 18X22X1
170819	SUPPORT FOR HANDLE 600 NE
180644	NG DOOR RAIL WITH BRAKE
190154	BRAKE
190651	BUSH
190920	CURTAIN FOR ECORINSE NG-910X44
200402	SELF-ADHES.RUBB.SPONGE STRIPS
200478	SELF-ADHESIVE GASKET 65X4
210202	RUBBER FOOT GLASSWASHER
260250	SCREW TB 5X20
260253	SCREW 5X35
260404	STAINLESS STEEL NUTS D6 UNI 55
260414	SELF-LOCKING NUT M5
260503	STAINL.STEEL FLAT WASHER D5 UN
260513	GROWER WASHER D8
260538	WASHER 18X6X1,5 ST/ST
322294	SUPPORT
322297	SUPPORT
322338	COVER 600MM NG2
323011	DOOR 600MM NG2
330715	UPPER BRACKET CURTAIN SNL-SE
331067	DOOR HANDLE 600 NE02
331430	BRACKET FOR DOOR SPRING
331973	DOOR MICRO SWITCH BRACKET
331974	SUPPORT FOR DOOR HOOK
341210	CURTAIN SHAFTS N 2S GM
342538	HOOD 600MM NG2
351642	PANEL 600MM NE
351691	DOOR PANEL 600
351929	PANEL 600
391309	DOOR SPRING 4KG - 40MM
391331	SPRING ASSEMBLY KG. 5 MM 40
411001	PERMANENT MAGNET 8X40
450220	SPRING

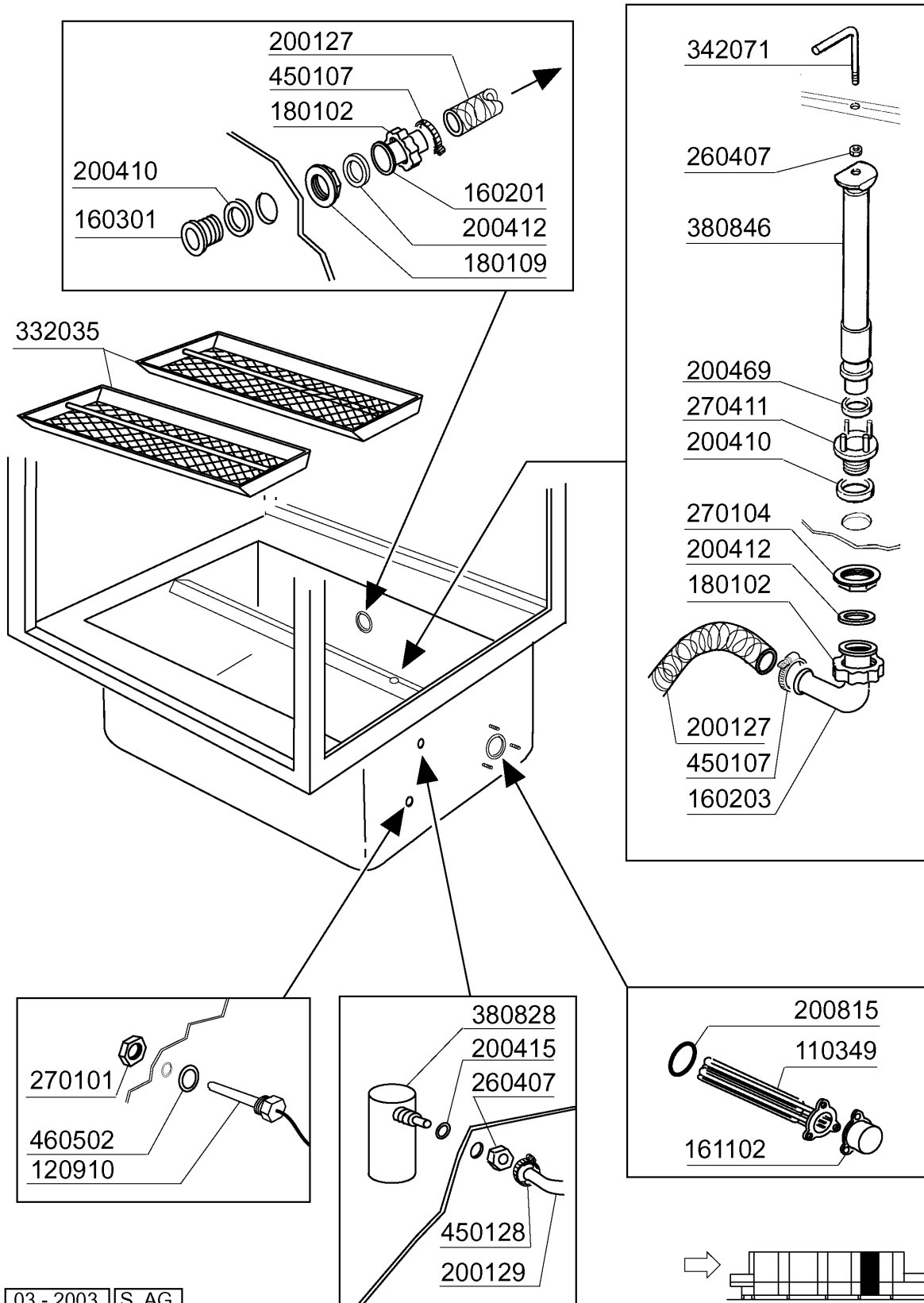

12 - Ecorinse Tank

CODE	DESCRIPTION
110349	HEAT.ELEMENT 6000W 230/400V
120910	ELECTRONIC TOUCH PAD CONTROLS
160201	ELBOW F.TANK INLET MOPLN
160203	ELBOW 1"1/2 N-S-F-C /DRAIN
160301	DRAIN OUTLET 1"1/2 C-S-N
161102	ELEMENT COVER MOPL.
180102	DRAIN PIPE NUT 1"1/2 F45-55
180109	LOCK NUT 1 1/2"
200127	PVC HOSE D.35
200129	HOSE 5X11 FOR PRESSURE SWITCH
200410	DRAIN OUTL.WASH.1 1/2"65X47X2
200412	GASKET DRAIN 11/2" 45X33X3
200415	AIR TRAP GASKET -F2 18,5X10X3
200469	STAND PIPE O RING 45X35,5X7
200815	O-RING F. HEAT.ELEM.
260407	STAINLESS STEEL NUTS D10 UNI 5
270101	HEXAGON LOCK NUT 1/2"
270104	LOCK NUT 1" 1/2
270411	DRAIN OUTLET F. PREWASH/ECOR.
332035	ECORINSE TANK FILTER XL
342071	ECORINSE ROD NE02
380828	ECORINSE AIR CHAMBER AC-ACR ST
380846	OVERFLOW PIPE ECORINSE TANK NE
450107	CLAMP FE ZN 38-50 H=12,2
450128	CLAMP
460502	GASKET 30X21X2

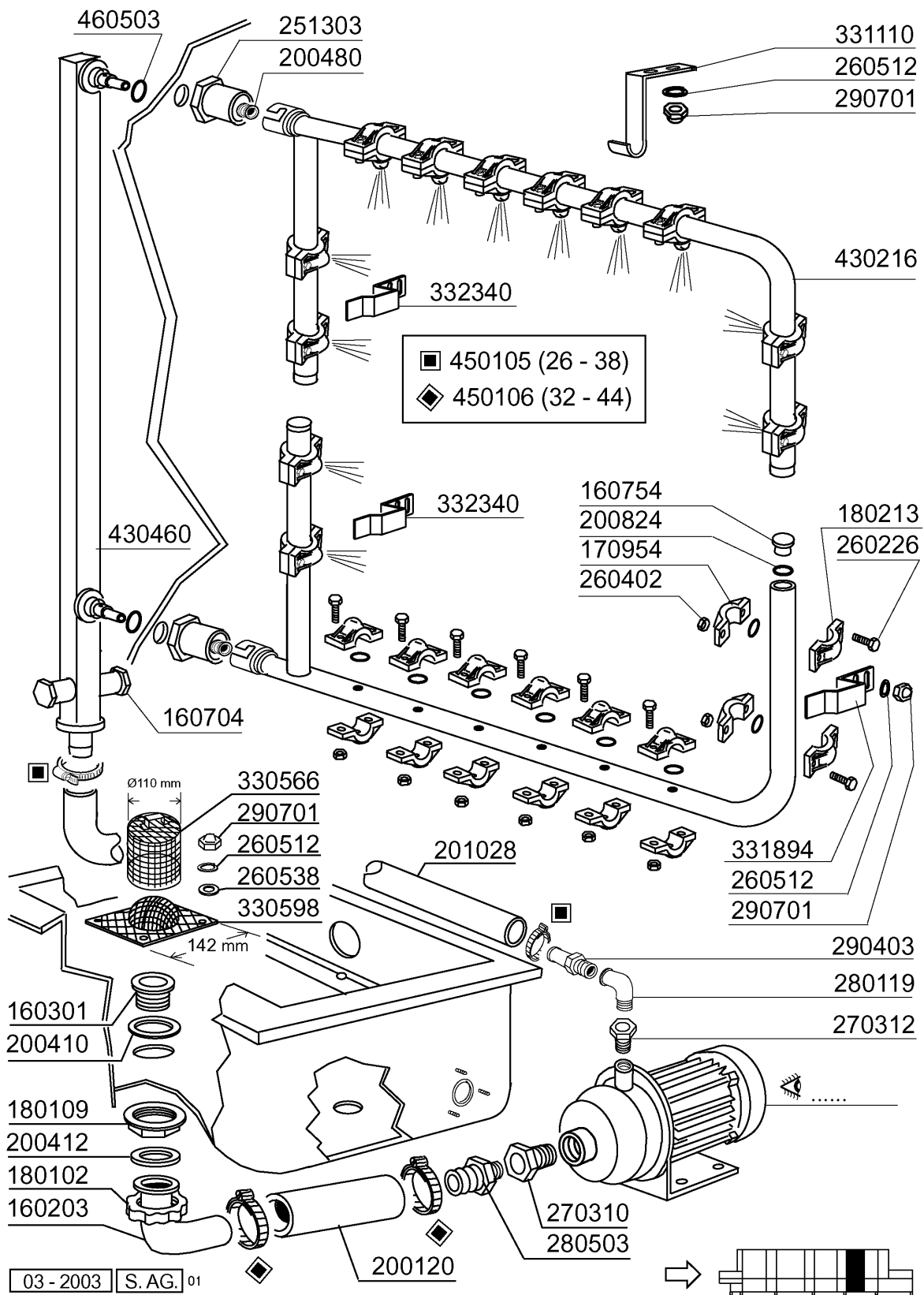

13 - Ecorinse Assembly

CODE	DESCRIPTION
160203	ELBOW 1"1/2 N-S-F-C /DRAIN
160301	DRAIN OUTLET 1"1/2 C-S-N
160704	BLACK PLUG WITH GASKET 1/2"GAK
160754	PLUG FOR RINSE ARMS SE NE
170954	JET FOR ECORINSE ARM
180102	DRAIN PIPE NUT 1"1/2 F45-55
180109	LOCK NUT 1 1/2"
180213	FLANGE F.JET LOCKING F2-C34
200120	RUBBER HOSE 35X48
200410	DRAIN OUTL.WASH.1 1/2"65X47X2
200412	GASKET DRAIN 11/2" 45X33X3
200480	GASKET F. RINSE CONNECT.
200824	O-RING 1,78X12,42X15,98
201028	OUTLET HOSE F. PREWASH 400MM A
251303	NUT
260226	STAINL.ST TCP SCREW 4X12 A2 UN
260402	STAINLESS STEEL NUT D4 UNI 55
260512	ST/ST GROWER WASHER D6
260538	WASHER 18X6X1,5 ST/ST
270310	CONNECTION 1"1/4-1/2"
270312	CONNECT.1" - 3/4"
280119	ELL MF 3/4"
280503	CONNECTIO FOR ECORINSE PUMP
290403	NIPPLE M.3/4" BRASS
290701	HEXAGON BLIND NUTS GM H12
330566	FILTER 110 FOR ECORINSE TANK
330598	ECORINSE FILTER
331110	SUPPORT.HOOK F.UPPER RINSE ARM
331894	BRACKET
332340	SQUADR FERMO BRACCI RISC.NG/2
430216	ECORINSE ARM NG2
430460	ECORINSE COLUMN NG2
450105	CLAMP FE ZN. 26-38 H=12,2
450106	CLAMP FE ZN 32-44 H=12,2
460503	SEALING WASHER 38X27X2(3/4)

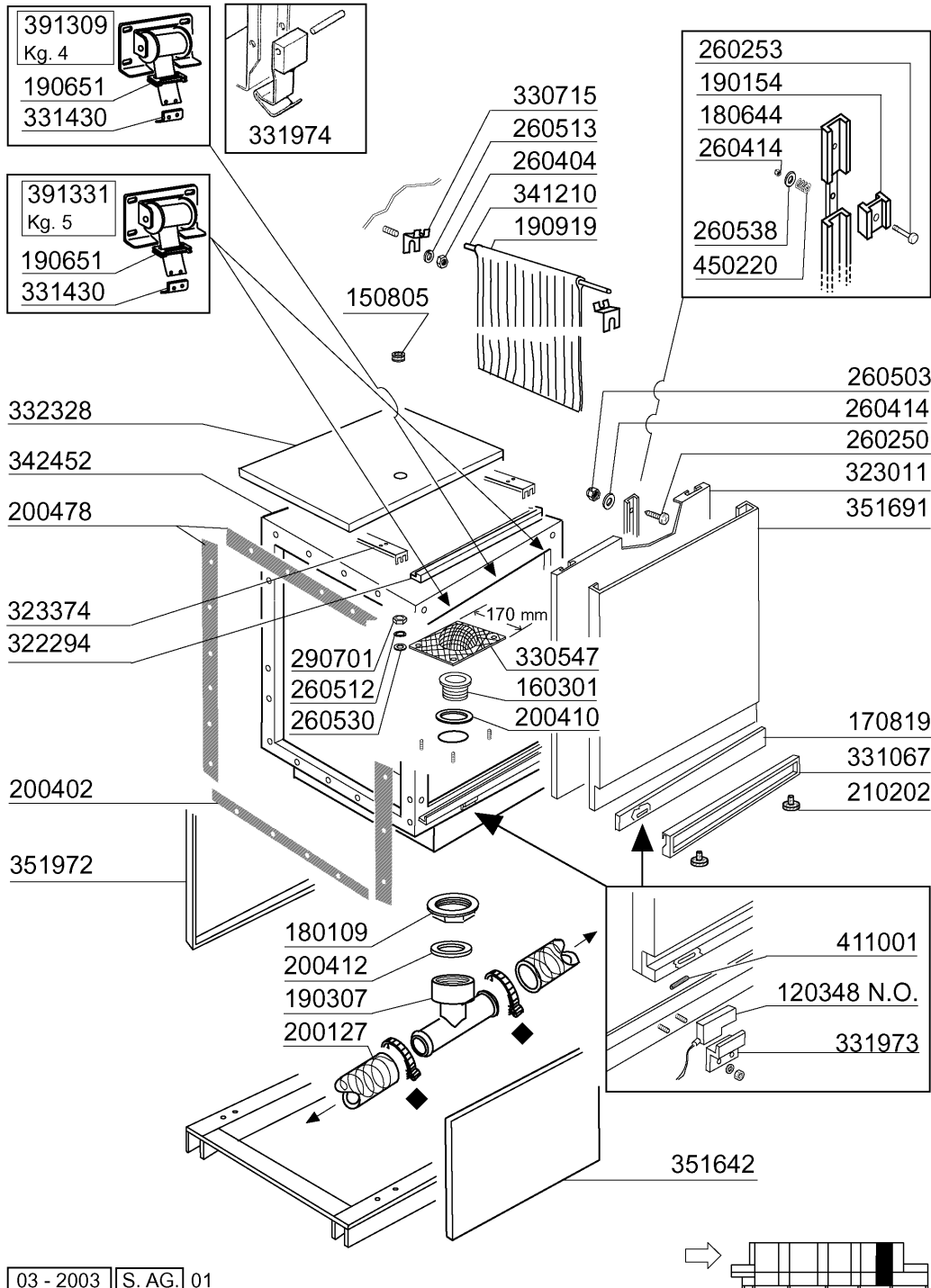

14 - Rinse Hood 600mm

CODE	DESCRIPTION
120348	MAGN.SWITCH (N.O.)
150805	CABLE HOLDER 18X22X1
160301	DRAIN OUTLET 1"1/2 C-S-N
170819	SUPPORT FOR HANDLE 600 NE
180109	LOCK NUT 1 1/2"
180644	NG DOOR RAIL WITH BRAKE
190154	BRAKE
190307	SPECIAL TEE GRAU MPL.
190651	BUSH
190919	MIDDLE CURTAIN NG-910X680
200127	PVC HOSE D.35
200402	SELF-ADHES.RUBB.SPONGE STRIPS
200410	DRAIN OUTL.WASH.1 1/2"65X47X2
200412	GASKET DRAIN 11/2" 45X33X3
200478	SELF-ADHESIVE GASKET 65X4
210202	RUBBER FOOT GLASSWASHER
260250	SCREW TB 5X20
260253	SCREW 5X35
260404	STAINLESS STEEL NUTS D6 UNI 55
260414	SELF-LOCKING NUT M5
260503	STAINL.STEEL FLAT WASHER D5 UN
260512	ST/ST GROWER WASHER D6
260513	GROWER WASHER D8
260530	STAINL.ST WASHER 7X22X2
260538	WASHER 18X6X1,5 ST/ST
290701	HEXAGON BLIND NUTS GM H12
322294	SUPPORT
323011	DOOR 600MM NG2
323374	SUPPORT
330547	FILTER F.TANK DRAIN NE/NG BTM
330715	UPPER BRACKET CURTAIN SNL-SE
331067	DOOR HANDLE 600 NE02
331430	BRACKET FOR DOOR SPRING
331973	DOOR MICRO SWITCH BRACKET
331974	SUPPORT FOR DOOR HOOK
332328	BRACKET
341210	CURTAIN SHAFTS N 2S GM
342452	HOOD 400MM NG2
351642	PANEL 600MM NE
351691	DOOR PANEL 600
351972	PANEL 600
391309	DOOR SPRING 4KG - 40MM
391331	SPRING ASSEMBLY KG. 5 MM 40
411001	PERMANENT MAGNET 8X40
450220	SPRING

15 - Rinse Assembly 600mm

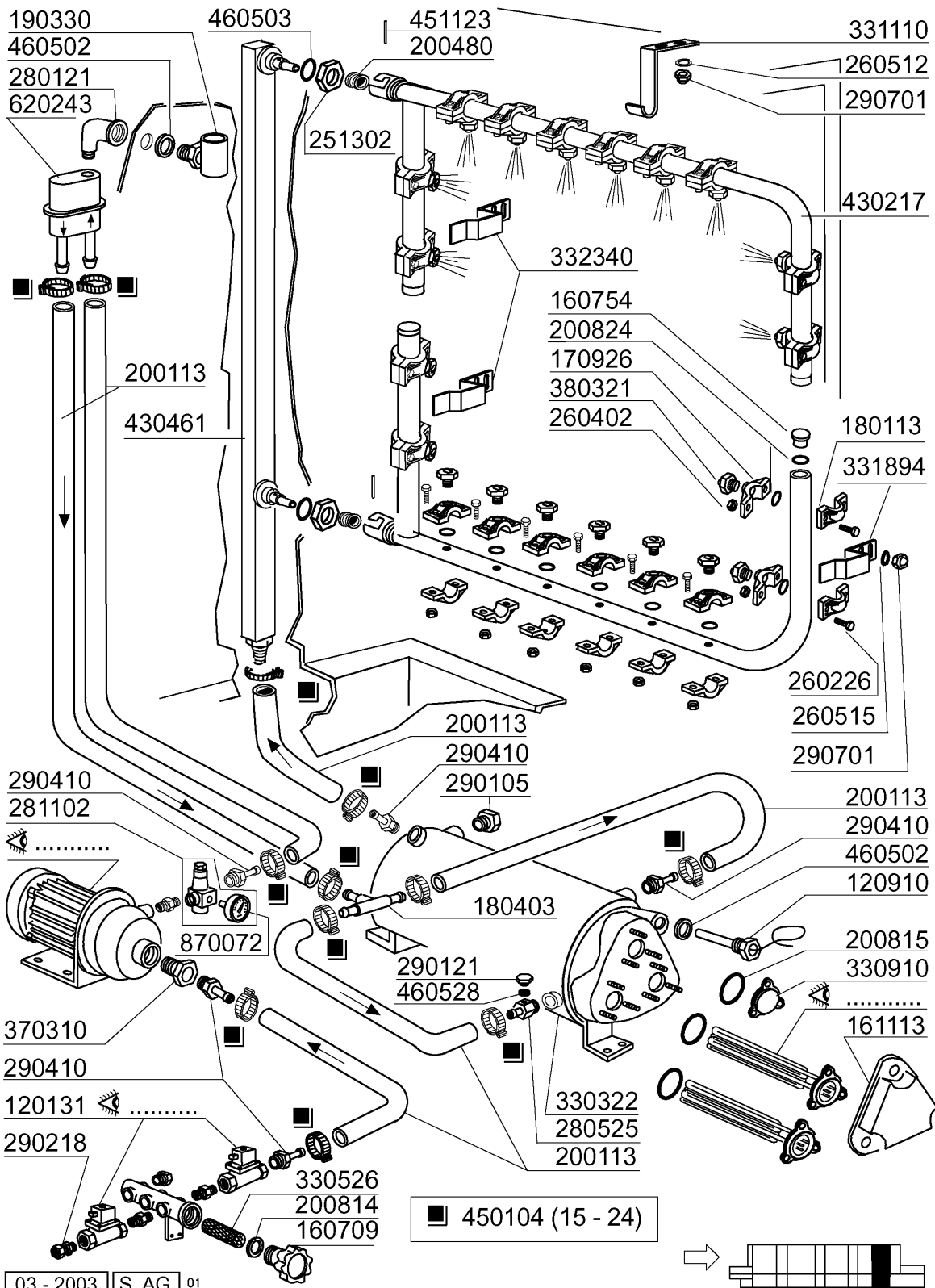

15 - Rinse Assembly 600mm

CODE	DESCRIPTION
120131	SOLEN. L182Q31-ZB10A 1/2"24V
120910	ELECTRONIC TOUCH PAD CONTROLS
160709	KNOB OF MANIFOLD F. SOLEN. VAL
160754	PLUG FOR RINSE ARMS SE NE
161113	ELEMENT COVER BLACK
170926	RINSE JET HOLDER S-SE-NE
180113	NUT
180403	TEE-NIPPLE F2-F300-B10-11
190330	TEE FOR VAACUM BREAKER
200113	RUBBER HOSE 12 X 22
200480	GASKET F. RINSE CONNECT.
200814	O-RING 34,52X41,58X3,53
200815	O-RING F. HEAT.ELEM.
200824	O-RING 1,78X12,42X15,98
251302	S/S LOCK NUT 3/4" AC-ACR
260226	STAINL.ST TCP SCREW 4X12 A2 UN
260402	STAINLESS STEEL NUT D4 UNI 55
260512	ST/ST GROWER WASHER D6
260515	GROWER WASHER D12
280121	ELL FOR VAACUM BREAKER
280525	NIPPLE
281102	1/2" ADJ VALVE C/W GAUGE TYPE
290105	BRASS-TE-PLUG 1/2"
290121	BRASS PLUG 1/8"
290218	NIPPLE 12X1/2"
290410	NIPPLE 1/2"
290701	HEXAGON BLIND NUTS GM H12
330322	INSULATED BOILER D.230 N/S
330526	FILTERS 22X28 SOLENOID V.MANIF
330910	FLANGE
331110	SUPPORT.HOOK F.UPPER RINSE ARM
331894	BRACKET
332340	SQUADR FERMO BRACCI RISC.NG/2
370310	CONVEYOR END RUN ARM NEXL
380321	RINSE JETS OV 1/8" 303 40LT 80
430217	RINSE ARM NG2
430461	RINSE COLUMN NG2
450104	CLAMP FE ZN H=12,5 15-24
451123	ELASTIC PIN 4X16
460502	GASKET 30X21X2
460503	SEALING WASHER 38X27X2(3/4)
460528	GASKET 15X10X2 FOR RINSE NIPPE
620243	VACUUM BREAKER (WITHOUT KIT)
870072	PRESSURE CAUGE 0-4 ATM

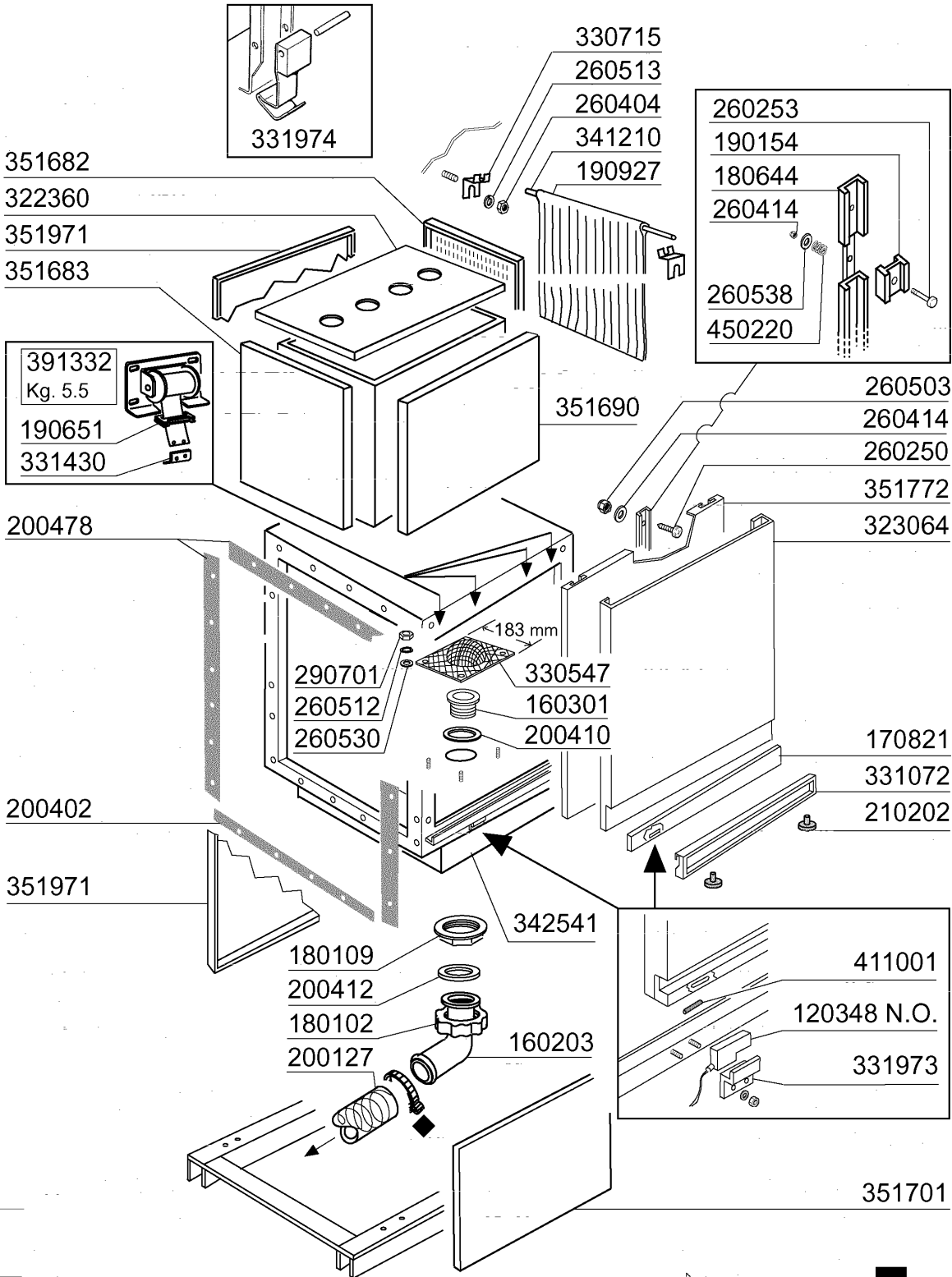

03 - 2003 | S. AG.

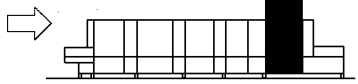

16 - Dryer hood 1000mm

CODE	DESCRIPTION
120348	MAGN.SWITCH (N.O.)
160203	ELBOW 1"1/2 N-S-F-C /DRAIN
160301	DRAIN OUTLET 1"1/2 C-S-N
170821	SUPPORT FOR HANDLE NE2 1000MM
180102	DRAIN PIPE NUT 1"1/2 F45-55
180109	LOCK NUT 1 1/2"
180644	NG DOOR RAIL WITH BRAKE
190154	BRAKE
190651	BUSH
190927	CURTAIN
200127	PVC HOSE D.35
200402	SELF-ADHES.RUBB.SPONGE STRIPS
200410	DRAIN OUTL.WASH.1 1/2"65X47X2
200412	GASKET DRAIN 11/2" 45X33X3
200478	SELF-ADHESIVE GASKET 65X4
210202	RUBBER FOOT GLASSWASHER
260250	SCREW TB 5X20
260253	SCREW 5X35
260404	STAINLESS STEEL NUTS D6 UNI 55
260414	SELF-LOCKING NUT M5
260503	STAINL.STEEL FLAT WASHER D5 UN
260512	ST/ST GROWER WASHER D6
260513	GROWER WASHER D8
260530	STAINL.ST WASHER 7X22X2
260538	WASHER 18X6X1,5 ST/ST
290701	HEXAGON BLIND NUTS GM H12
322360	DRYER COVER 1000MM NG2
323064	DOOR 1000MM DRYER NG2
330547	FILTER F.TANK DRAIN NE/NG BTM
330715	UPPER BRACKET CURTAIN SNL-SE
331072	DOOR HANDLE 1000MM NE2
331430	BRACKET FOR DOOR SPRING
331973	DOOR MICRO SWITCH BRACKET
331974	SUPPORT FOR DOOR HOOK
341210	CURTAIN SHAFTS N 2S GM
342541	HOOD 1000MM DRYER NG2
351682	DRYER PANEL
351683	BACK PANEL FOR DRYER
351690	FRONT PANEL 1000
351701	PANEL 1000
351772	DOOR PANEL 1000
351971	PANEL 1000
391332	DOOR SPRING 5,5 KG - 40MM
411001	PERMANENT MAGNET 8X40
450220	SPRING

17 - Blower Dryer - electric version 1000mm

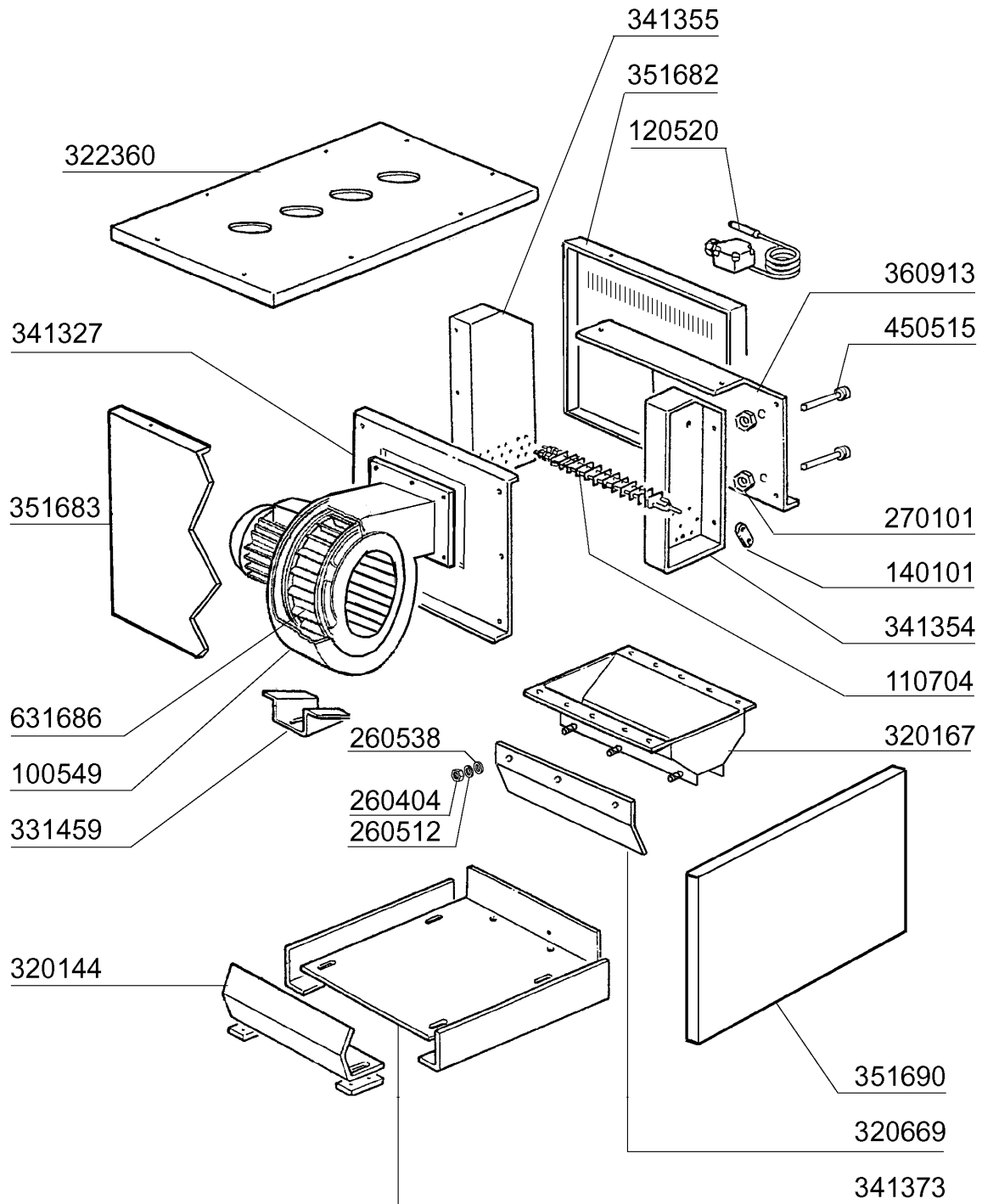

03 - 2003 | S. AG.

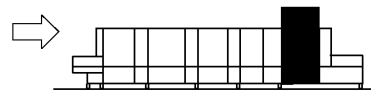

17 - Blower Dryer - electric version 1000mm

CODE	DESCRIPTION
100549	DRYER VENTILATOR 3HP NG - NEXL
110704	HEAT.ELEMENT/DRYING 1000W 220V
120520	SECURITY THERMOSTAT 110-130Ø
140101	BRASS CONNECT. PLATE HEAT.ELEM
260404	STAINLESS STEEL NUTS D6 UNI 55
260512	ST/ST GROWER WASHER D6
260538	WASHER 18X6X1,5 ST/ST
270101	HEXAGON LOCK NUT 1/2"
320144	DRYER DEFLECTOR
320167	AIR OUTLET BAFFLE NG-NEXL
320669	FIXING PLATE
322360	DRYER COVER 1000MM NG2
331459	BRACKET FOR DRYING VENTILATOR
341327	FAN SUPPORT
341354	RIGHT SUPPORT FOR DRYER 18KW 1
341355	LEFT SUPPORT FOR DRYER 18KW 10
341373	PANEL
351682	DRYER PANEL
351683	BACK PANEL FOR DRYER
351690	FRONT PANEL 1000
360913	BACK PANEL 1000MM NE XL
450515	STAINL.ST.SHIELD FOR 1 THERMOS
631686	FAN IMPELLOR FOR FLIGHT VRP25/

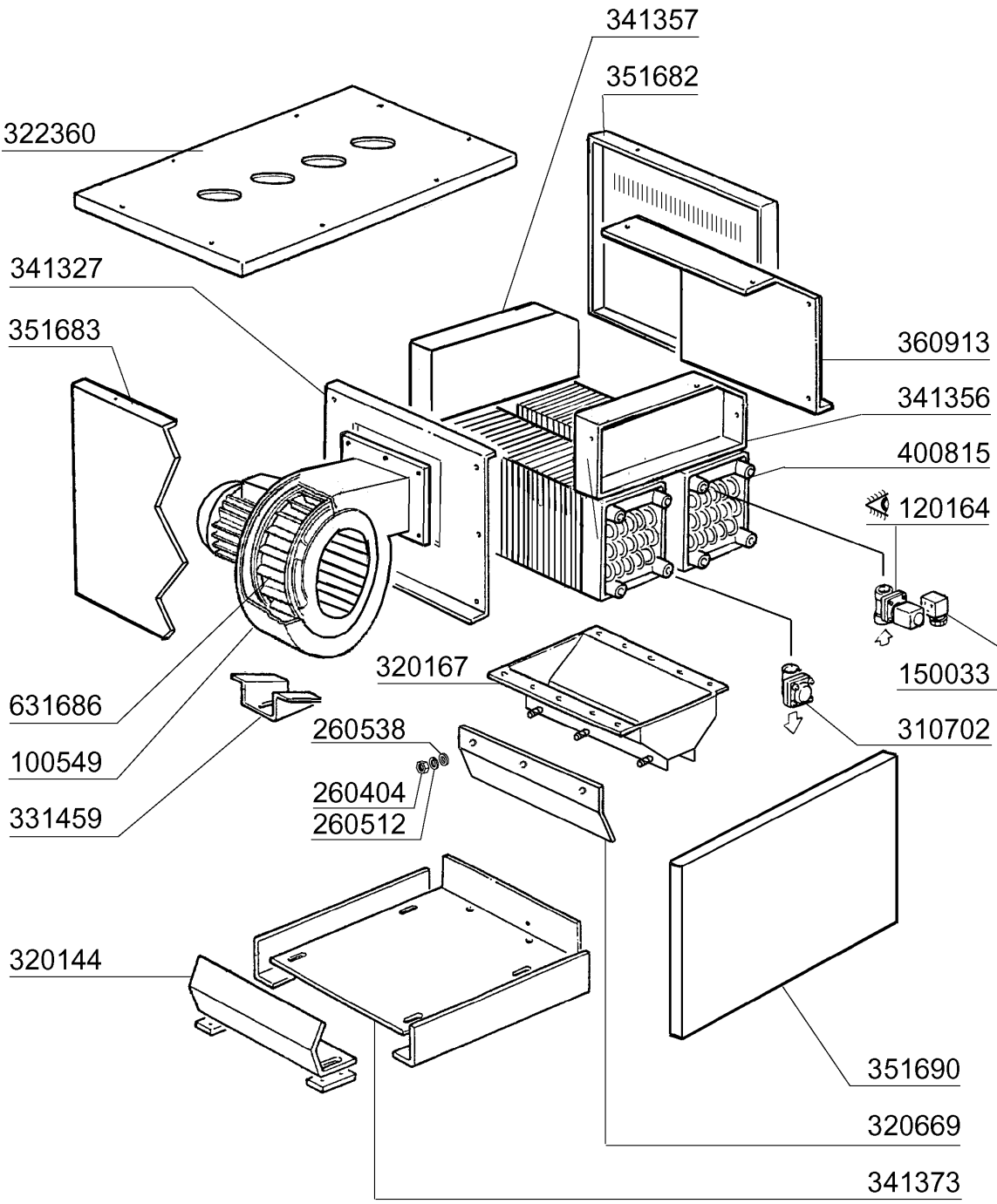

03 - 2003 S. AG.

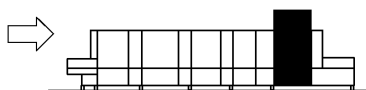

18 - Steam Blower Dryer 1000

CODE	DESCRIPTION
100549	DRYER VENTILATOR 3HP NG - NEXL
120164	SOLE.N.VALVE ST.24V50HZ 1/2"
150033	CONNEC.F.SOLEN.VALVE 182.09.N
260404	STAINLESS STEEL NUTS D6 UNI 55
260512	ST/ST GROWER WASHER D6
260538	WASHER 18X6X1,5 ST/ST
310702	STEAM TRAP 1/2" MK 25/3
320144	DRYER DEFLECTOR
320167	AIR OUTLET BAFFLE NG-NEXL
320669	FIXING PLATE
322360	DRYER COVER 1000MM NG2
331459	BRACKET FOR DRYING VENTILATOR
341327	FAN SUPPORT
341356	RIGHT PANEL
341357	LEFT PANEL
341373	PANEL
351682	DRYER PANEL
351683	BACK PANEL FOR DRYER
351690	FRONT PANEL 1000
360913	BACK PANEL 1000MM NE XL
400815	BATTERY FOR DRYING (9-12KW) SE
631686	FAN IMPELLOR FOR FLIGHT VRP25/

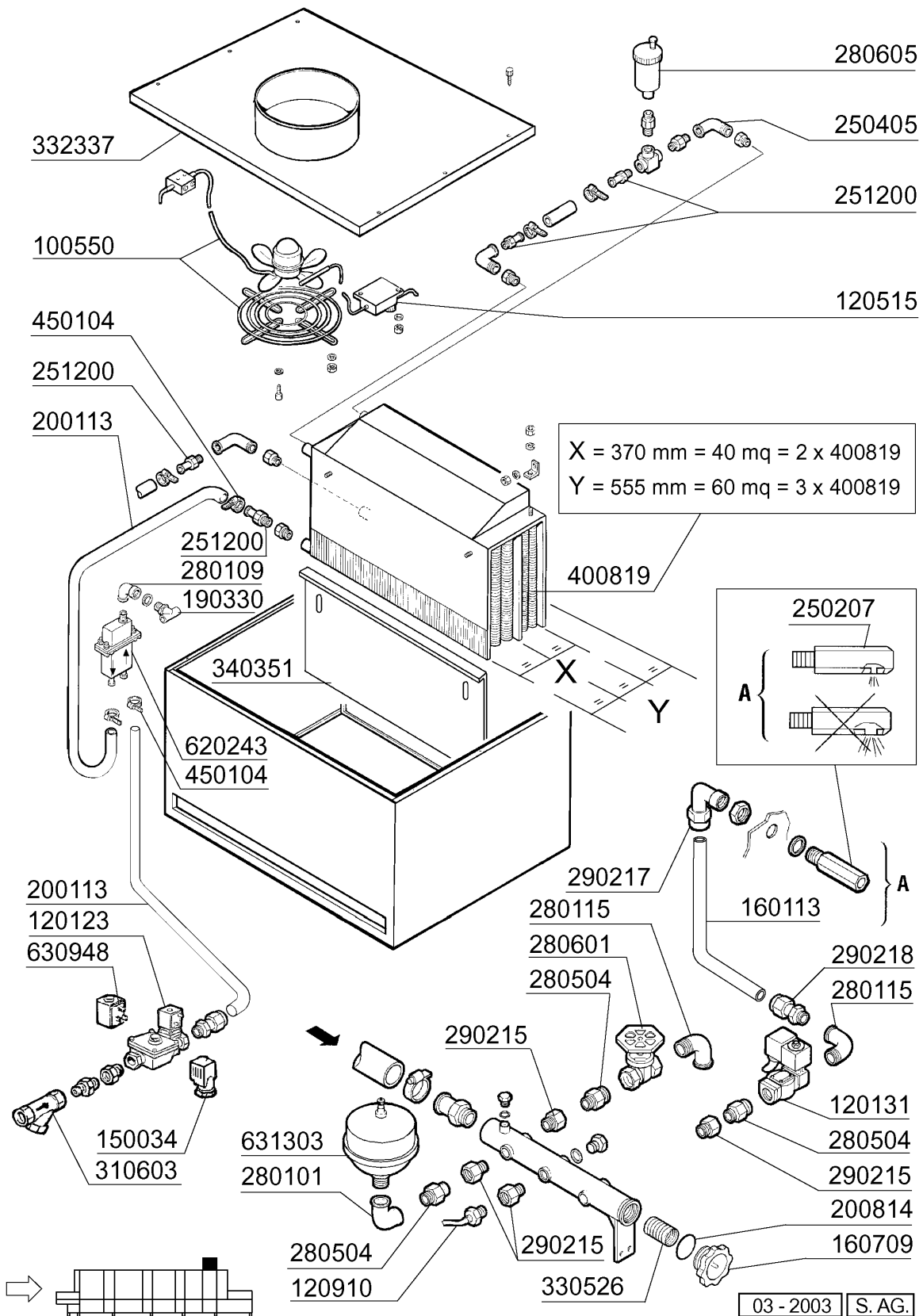

19 - Heat recovery unit

CODE	DESCRIPTION
100550	FAN FOR HEAT RECOVERY UNIT
120123	SOLENOID VALVE L180B12 1" V.24
120131	SOLEN. L182Q31-ZB10A 1/2"24V
120515	THERMOSTAT 0-90°C
120910	ELECTRONIC TOUCH PAD CONTROLS
150034	CONNEX.F.SOLEN.VALVE 122.09.N
160113	TUBE IN POL. RETIC. 12 EST
160709	KNOB OF MANIFOLD F. SOLEN. VAL
190330	TEE FOR VACUUM BREAKER
200113	RUBBER HOSE 12 X 22
200814	O-RING 34,52X41,58X3,53
250207	SPEC.NUTS F.DOOR ROD AISI 303
250405	INOX ELL MF 1/2"
251200	S/S NIPPLE 1/2"
280101	CRANK F.F 1/2"
280109	CRANK 90° F.F 3/8"
280115	ELL 1/2"
280504	MANIFOLD CONN.HOSE
280601	GATE VALVE 1/2" BRASS
280605	AUTOMATIC AIR VENT 1/4" GAS
290215	1/2"BSP M/F UNION BRASS
290217	HOSE CLAMP ELBOW 12X3/8" TYPE
290218	NIPPLE 12X1/2"
310603	STRAINERS JU 1" MOD.45
330526	FILTERS 22X28 SOLENOID V.MANIF
332337	BRACKET
340351	PANEL
400819	HRU BATTERY
450104	CLAMP FE ZN H=12,5 15-24
620243	VACUUM BREAKER (WITHOUT KIT)
630948	COIL Z610A 24V 50/60-L180V01
631303	HYDRAULIC AIR VESSEL FOR HEAT

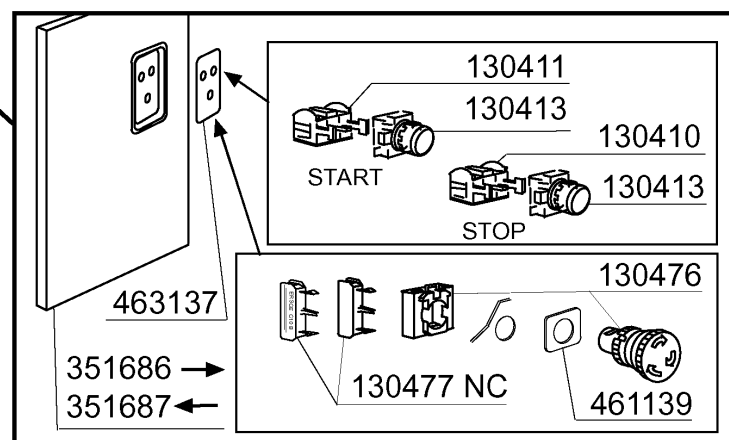
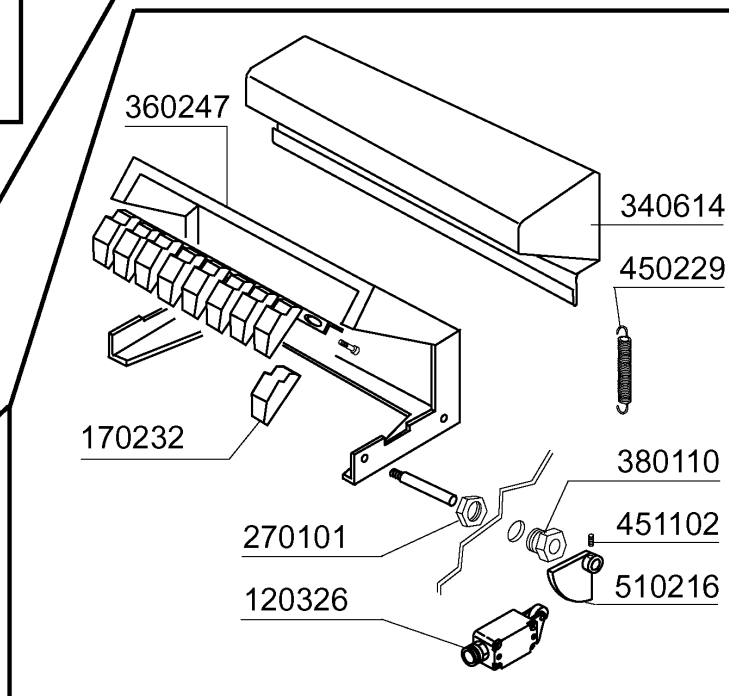
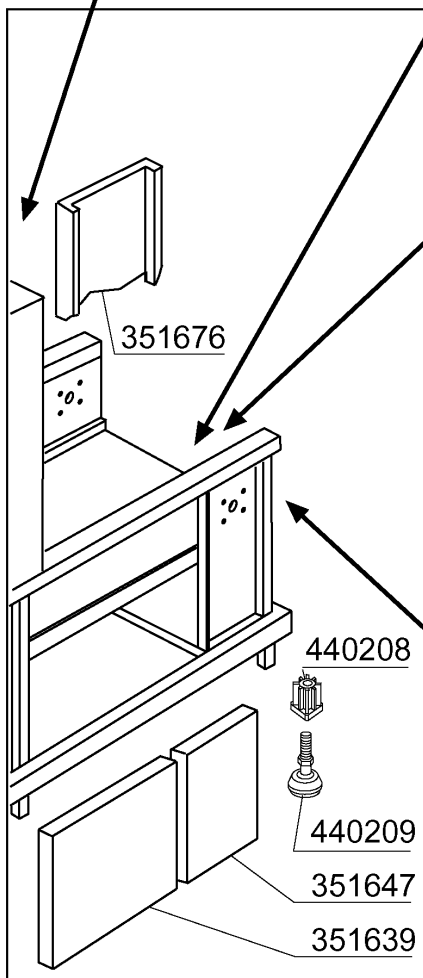
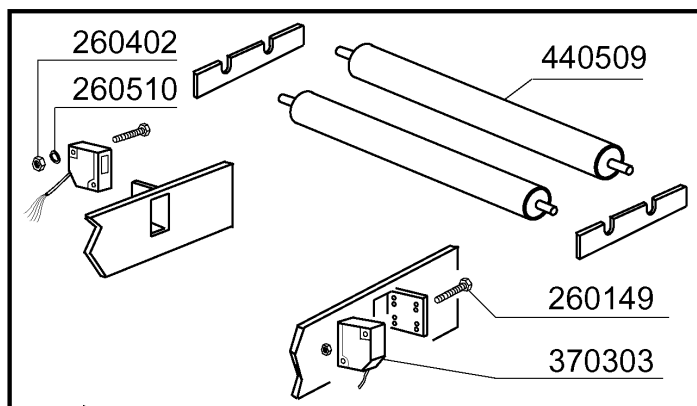
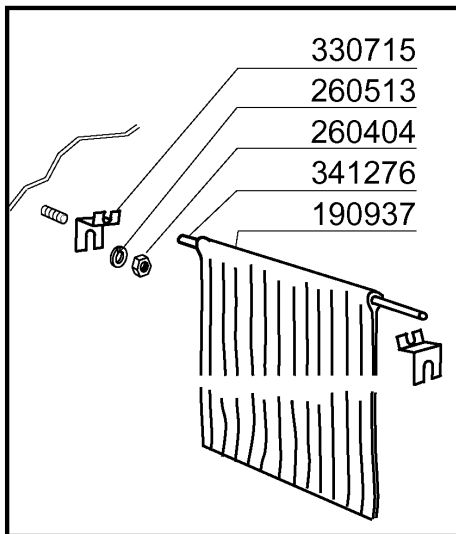

03 - 2003 | S. AG.

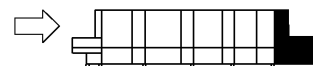

20 - Exit table / End run switch

CODE	DESCRIPTION
120326	MICRO SWITCH FD 102
130410	STOP CONTACT F40 CN RED
130411	START CONTACT YELLOW
130413	GREEN PUSH BUTTON
130476	ROTATIVE EMERGENCY SWITCH
130477	CONTACT NC
170232	PEG END RUN ARM
190937	NG EXIT CURTAIN
260149	SCREW TE 4X25
260402	STAINLESS STEEL NUT D4 UNI 55
260404	STAINLESS STEEL NUTS D6 UNI 55
260510	GROWER WASHER D.4
260513	GROWER WASHER D8
270101	HEXAGON LOCK NUT 1/2"
330715	UPPER BRACKET CURTAIN SNL-SE
340614	ENTRY TABLE COVER
341276	SPINDLE FOR CURTAIN NG
351639	PANEL 1000MM NE
351647	PANEL 500MM NE
351676	BACK PANEL 500MM
351686	RIGHT PANEL 500
351687	LEFT PANEL 500
360247	COVER FOR END RUN SWITCH
370303	PHOTOCELL
380110	BRASS BEARING D12 F.ECON.N
440208	FOOT INSERT
440209	COMPLETE FOOT NE
440509	S/S DISCHARGE ROLLER FOR NG
450229	STAINL.ST SPRING LIMIT SWITCH
451102	RINSE GATE PIN 3X26
461139	PLATE
463137	SELF ADHESIVE SYMBOL
510216	N RINSE GATE ECCENTRE

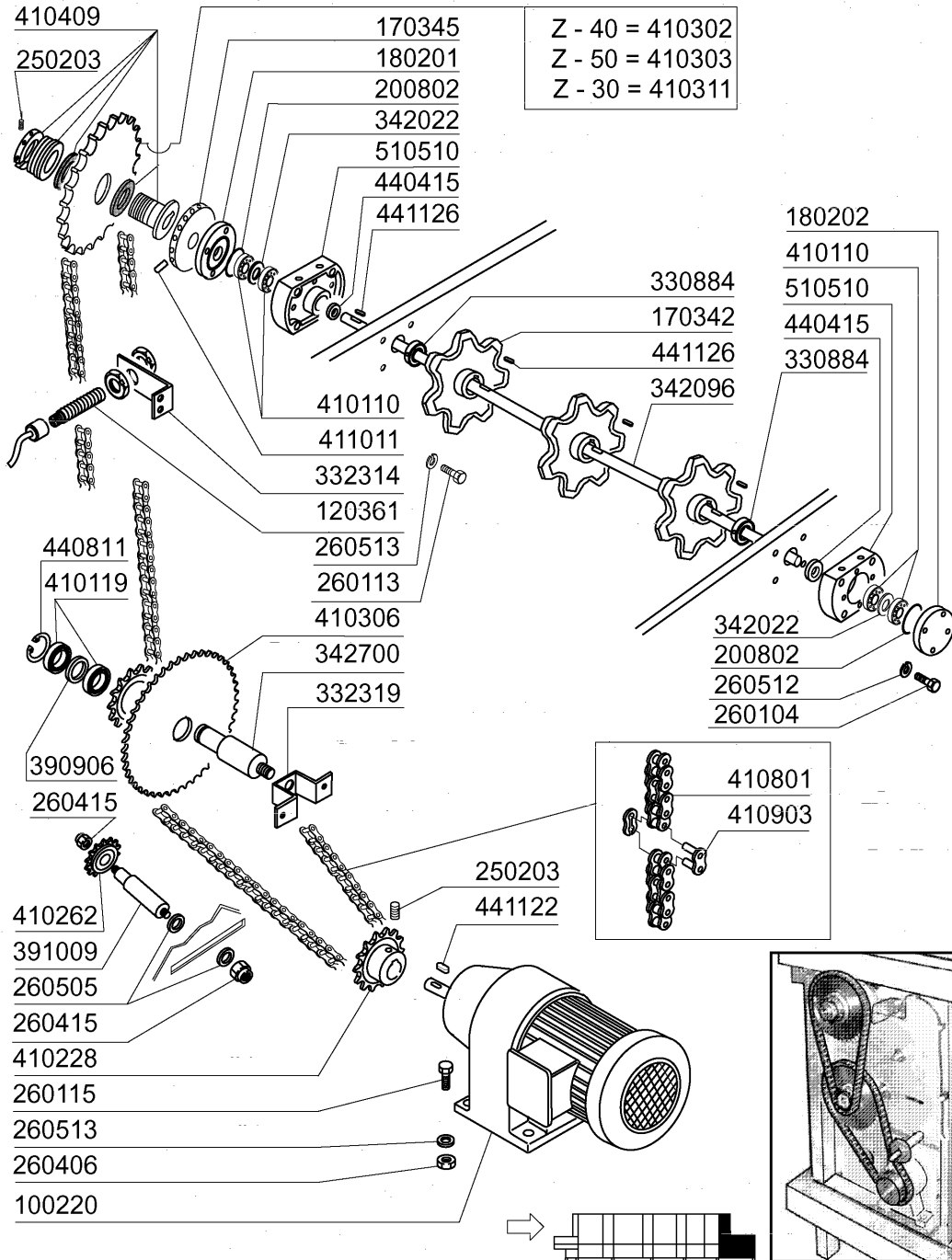

21 - Drive unit

CODE	DESCRIPTION
100220	DRIVE MOTOR KW0,12-220/380V/50
120361	SENSOR
170342	PINION
170345	WHEEL FOR MAGNETS
180201	DRILLED FLANGE 85 /DRIVE
180202	BLIND FLANGE D.85 (DRIVE) N
200802	OR GASKET 3,53X44,05X51,11
250203	GRUB SCREW 8X12
260104	STAINL.ST TE-SCREW A2 6X16 UNI
260113	STAINL.ST.TE SCREW 8X20 A2 UNI
260115	STAIN.ST.TE SCREW 8X20 A2 UNI
260406	NUT 8MA
260415	STAINLESS STEEL SELF-LOCKING N
260505	STAINL.STEEL FLAT WASHER D8
260512	ST/ST GROWER WASHER D6
260513	GROWER WASHER D8
330884	WASHER
332314	BRACKET
332319	BRACKET
342022	WASHER
342096	DRIVE SHAFT NG2
342700	PIN
390906	SPACER
391009	PIN
410110	BEARINGS 20X42X12 6004
410119	RADIAL BEARING 32X15X9
410228	TURNED PINION Z14-1/2"-D.19
410262	PINION Z13
410302	CROWN DISCS 40T 1/2" PITCH
410303	CROWN DISCS 50T 1/2" PITCH
410306	GROUP CROWN-SPROCKET Z14/40
410311	CROWN DISCS 30T 1/2"
410409	TORQUE LIMITER LC2
410801	DRIVE CHAIN 1/2" N-S
410903	CHAIN JOINT 1/2"
411011	MAGNET D.5X20
440415	GASKET MIM 20X30X5 (VITON)
440811	EXTERN.SEALING RING D.15 UNI 7
441122	DRIVE SHAFT KEY 6X6X25 UNI 660
441126	DRIVE SHAFT KEY 8X7X40
510510	DRIVE AXLE SUPPORT

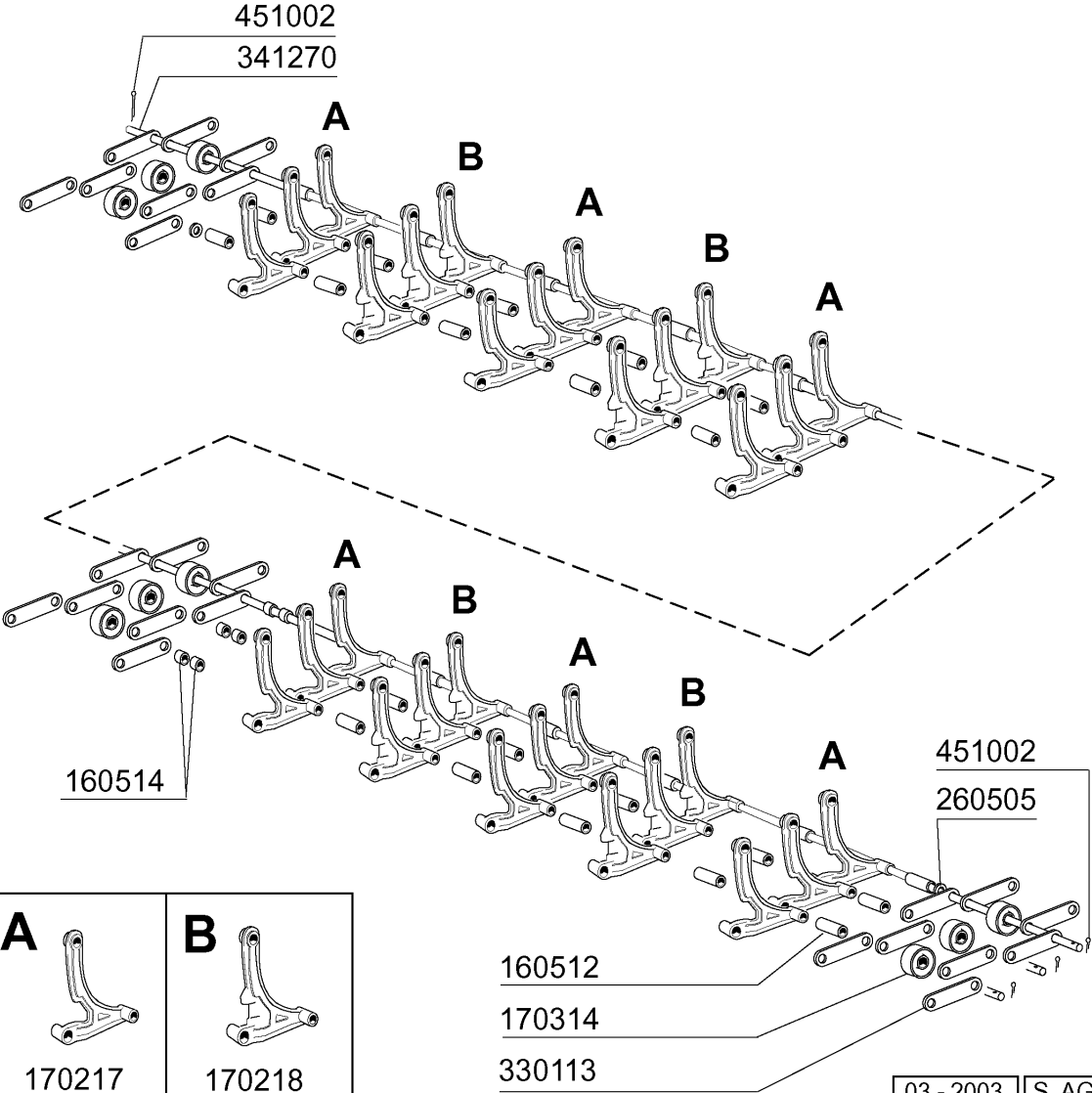
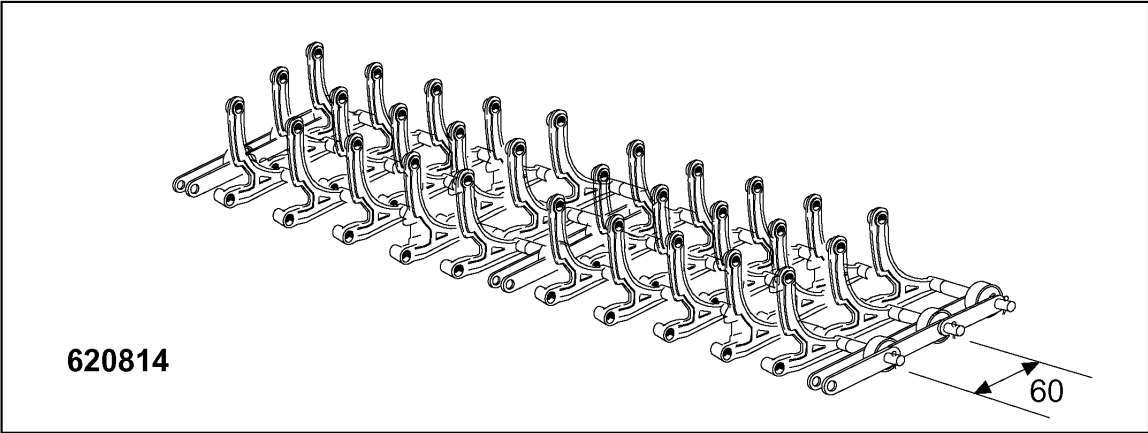

22 - Conveyor 60mm

CODE	DESCRIPTION
160512	SPACER 35,5
160514	SPACER 7,9 108378 MOP
170217	FINGER FOR BELT 60MM
170218	CENTRAL FINGER 60MM CONVEYOR B
170314	GRAY BELTWHEEL N
260505	STAINL.STEEL FLAT WASHER D8
330113	LINKS
341270	PIN
451002	COTTER PIN STAINL.ST. D2X12
620814	CONVEYOR BELT NEXL2

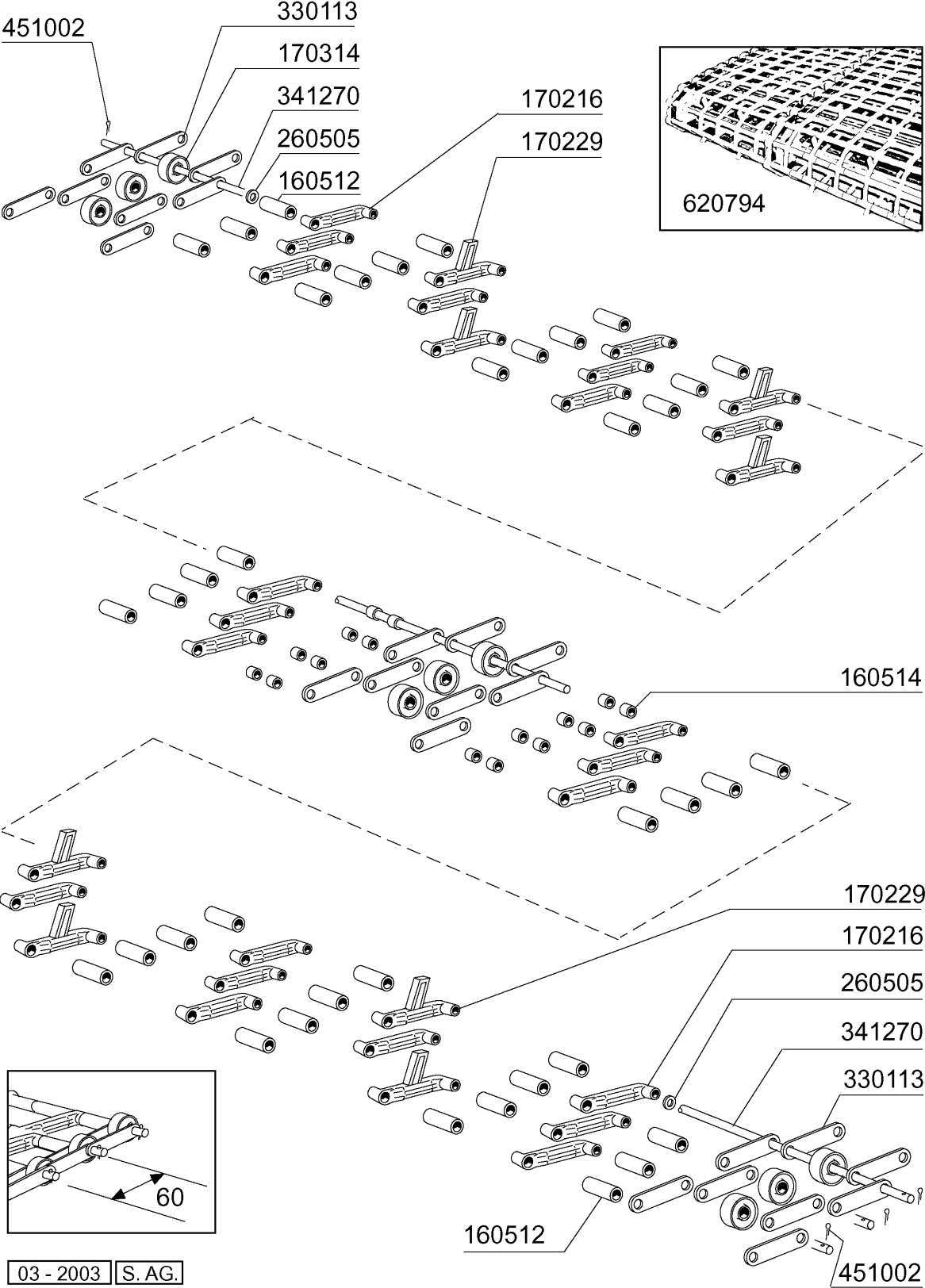

03 - 2003 | S. AG.

23 - Conveyor 60mm

CODE	DESCRIPTION
160512	SPACER 35,5
160514	SPACER 7,9 108378 MOP
170216	SPACER FOR BELT 60MM
170229	FINGER
170314	GRAY BELTWHEEL N
260505	STAINL.STEEL FLAT WASHER D8
330113	LINKS
341270	PIN
451002	COTTER PIN STAINL.ST. D2X12
620794	CONVEYOR BELT NG2 -60-

630529

631661 50 Hz (Ø 122)
631696 60 Hz

200848

630128

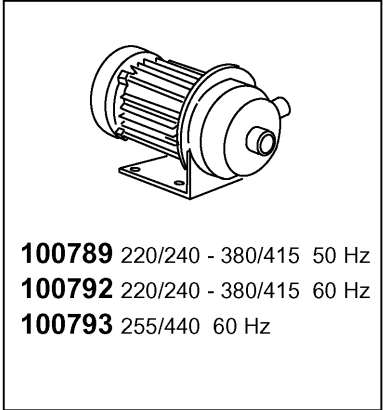
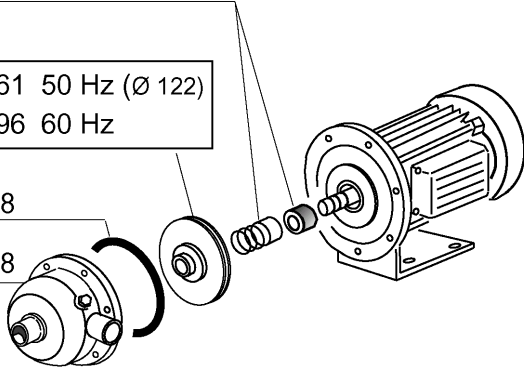

100789 220/240 - 380/415 50 Hz
100792 220/240 - 380/415 60 Hz
100793 255/440 60 Hz

HP 0,75 / Kw 0,55 (**CEA 120/2/A**)

630542

631697 (Ø 107)

630425

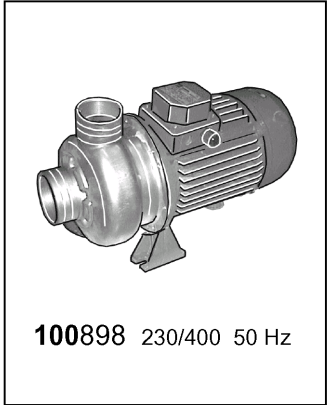
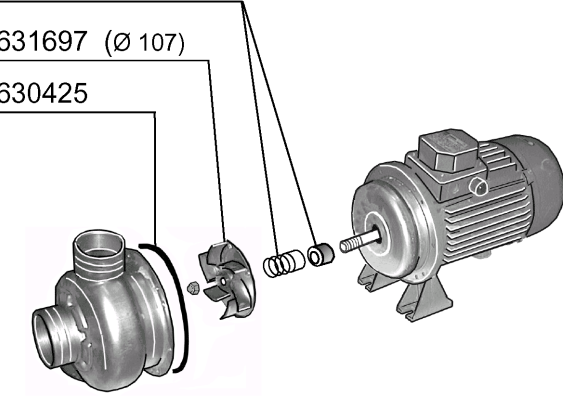

100898 230/400 50 Hz

HP 4 / Kw 3 (**DWO 400**)

24 - Pump

CODE	DESCRIPTION
100789	PUMP HP 0,75 220/415V
100792	PUMP HP 0,75 220/415
100793	PUMP HP 0,75
100898	PUMP 4 HP (NG-SERIES)
200848	O-RING FOR PUMP 0,75 HP CEA 12
630128	PUMP VOLUTE 0,75HP CEA120/2
630425	GASKET FOR PUMP 100770/78
630529	SEAL FOR PUMP HP0,75 CEA120/2A
630542	SEAL FOR WASH PUMP NG
631661	IMPELLER PUMP 0,75HP LOW.CE120
631696	IMPELLER 60HZ FOR PUMP 100792
631697	IMPELLER FOR PUMP 100770

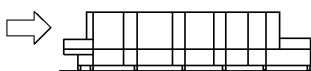
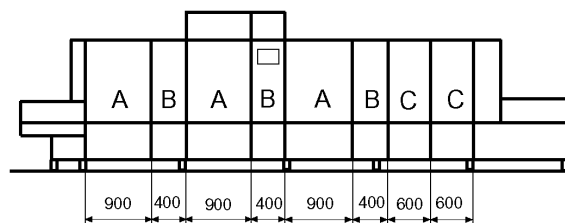
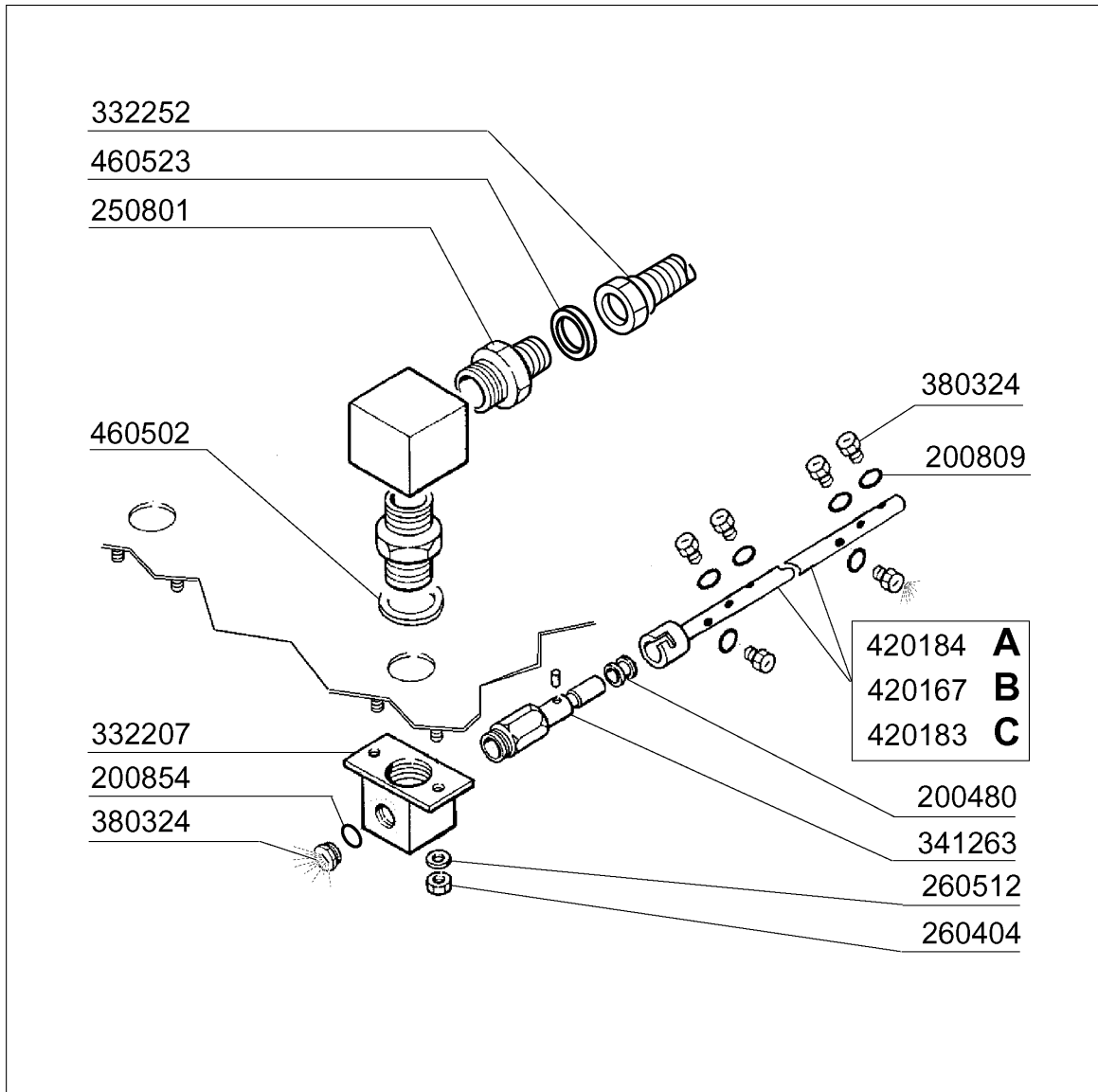

03 - 2003 | S. AG.

25 - Sanitising system

CODE	DESCRIPTION
200480	GASKET F. RINSE CONNECT.
200809	OR GASKET 1,78X8,73X12,29
200854	O-RING FOR NOZZLE OF S/S RINSE
250801	NIPPLES 1/2" INOX
260404	STAINLESS STEEL NUTS D6 UNI 55
260512	ST/ST GROWER WASHER D6
332207	NIPPLE
332252	HOSE 1/2"-220X420-
341263	PIN
380324	RINSE JETS 52,5 80Ø OV1/8"
420167	WASH ARM FOR SELF CLEANING
420183	SHORT WASH ARM FOR SELF CLEANI
420184	SPRAY ARM FOR SANITIZING 1000
460502	GASKET 30X21X2
460523	GASKET 10X18X2

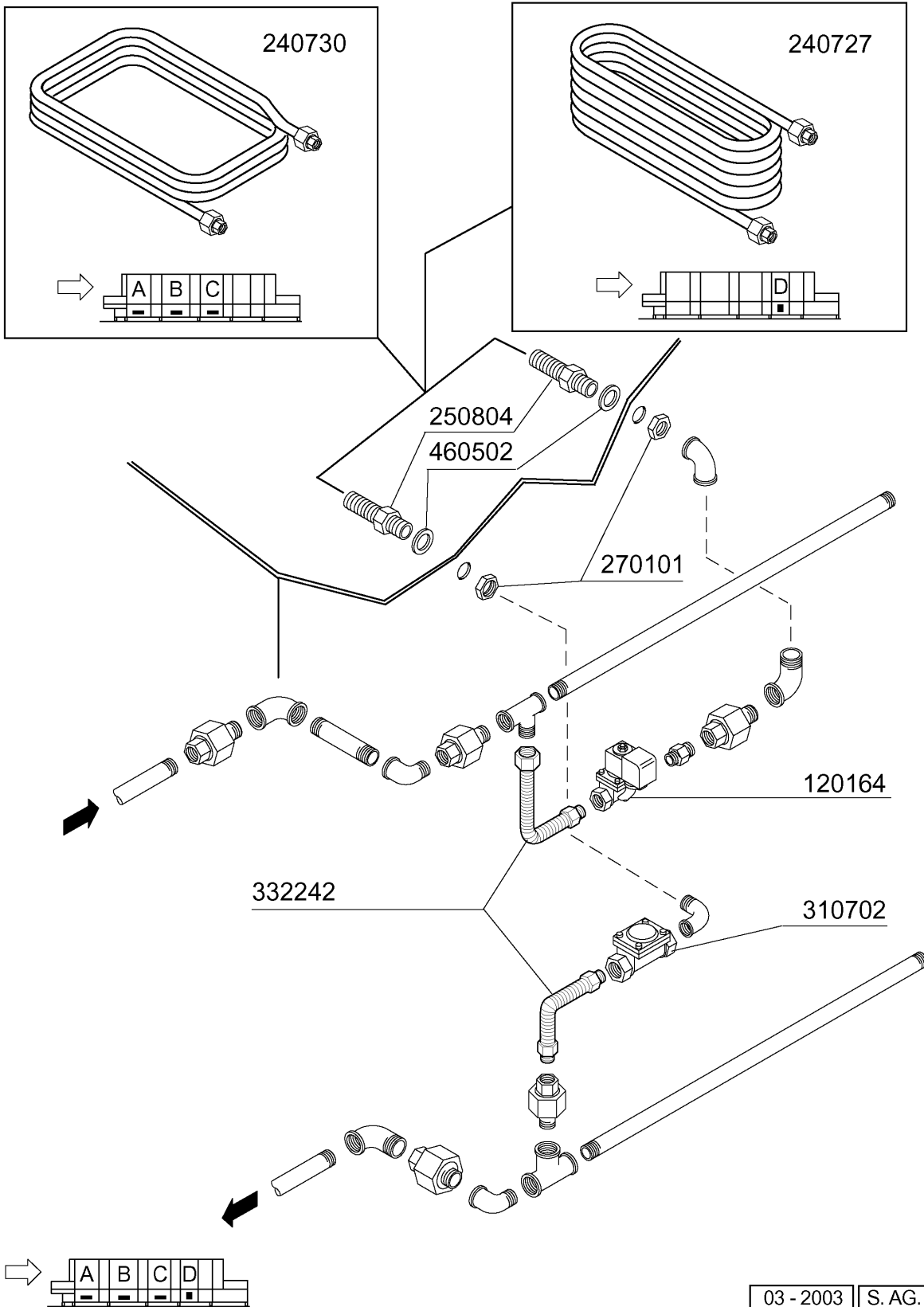

26 - Steam Version (Tank)

CODE	DESCRIPTION
120164	SOLE.N.VALVE ST.24V50HZ 1/2"
240727	STEAM COIL ECORINSE
240730	S/S STEAM COIL 18.000KCAL
250804	NIPPLES FOR STEAM COIL
270101	HEXAGON LOCK NUT 1/2"
310702	STEAM TRAP 1/2" MK 25/3
332242	HOSE 1/2"-130X220-
460502	GASKET 30X21X2

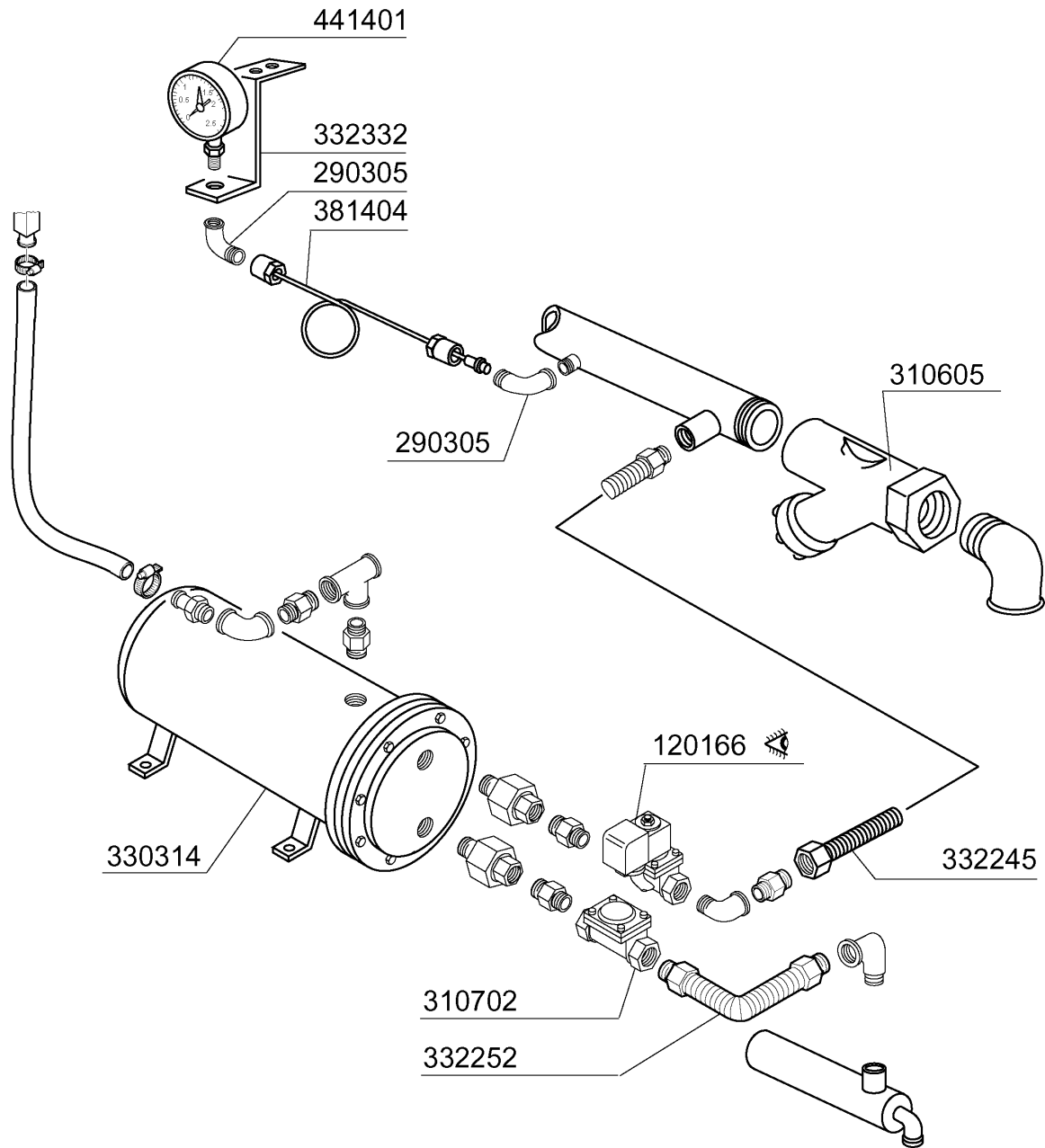

27 - Steam Version (Booster)

CODE	DESCRIPTION
120166	STEAM SOLEN.VALVE 1" 24V-50
290305	CONNECTION
310605	STRAINER JU 1 1/2" MOD.45
310702	STEAM TRAP 1/2" MK 25/3
330314	STEAM BOILER 30000 KCAL/H
332245	HOSE 1" 130X220
332252	HOSE 1/2"-220X420-
332332	BRACKET
381404	HOSE STEAM GAUGE
441401	PRESSURE GAUGE 60 SCALO-4CR1/4

ELETTROVALVOLA VAPORE - ELECTROVANNE VAPEUR - STEAM SOLENOID VALVE
DAMPF-VENTIL - ELECTROVALVULA VAPOR

150033

120166 (1")
120164 (1/2")

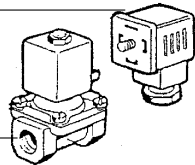

630976 (1")
630980 (1/2")



630629 (1")
630627 (1/2")

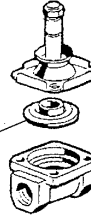

0 ÷ 2 bar

150033

120163 (1")
120161 (1/2")

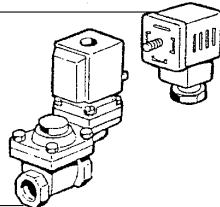

630972 (1")
630973 (1/2")



630626 (1")
630624 (1/2")

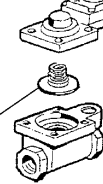

0,5 ÷ 2,5 bar

ELETTROVALVOLA ACQUA - ELECTROVANNE EAU - WATER SOLENOID VALVE
WASSER-VENTIL - ELECTROVALVULA AGUA

150034

120131 (1/2")

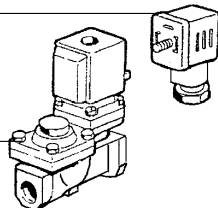

630948



630631
L180Q31

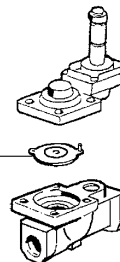

150034

120123 (1")

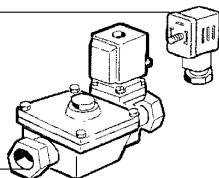

630948



630609
L180Q17







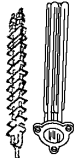
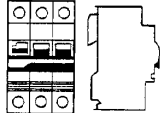
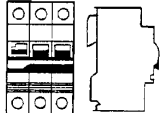

PER RECUPERATORE DI CALORE - POUR ECONOMISEUR D' ENERGIE
FÜR WÄRMERÜCKGEWINNUNG - FOR HEAT RECOVERY UNIT - PARA RECUPERADOR DE CALOR

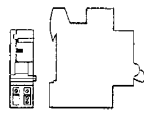
28 - Solenoid Valve

CODE	DESCRIPTION
120123	SOLENOID VALVE L180B12 1" V.24
120131	SOLEN. L182Q31-ZB10A 1/2"24V
120161	SOLEN.VAL.ST.L145R1Z734A 1/2
120163	SOLEN.VAL.ST.L145R1Z234A 1"24V
120164	SOLEN.VALVE ST.24V50HZ 1/2"
120166	STEAM SOLEN.VALVE 1" 24V-50
150033	CONNEC.F.SOLEN.VALVE 182.09.N
150034	CONNEC.F.SOLEN.VALVE 122.09.N
630609	DIAPHRAGM L180Q17-3/4
630624	KIT F.SOLEN.VALVE L145 1/2 G26
630626	KIT FOR SOLENOID VALVE 145 1"
630627	KIT F.SOLEN.V. L153D1 1/2"
630629	KIT SOLENOID VALVE 1" STEAM L1
630631	DIAPHRAGM SOL.VALVE
630948	COIL Z610A 24V 50/60-L180V01
630972	COIL Z534A/V.24-L145A-3/4
630973	COIL Z614A/V.24-L145-3/4 A
630976	COIL Z114A/V24/50HZ L153-1"
630980	COIL Z114 24V

	220/240 V				380/415 V			
								
KW	MAGNETOTERMICO RESISTENZA MAGNETO-TERMIQUE RÉSISTANCE TERMO-MAGNETIC SWITCH FOR HEATHER TERMO-MAGNETISCHER SCHALTER F. EIZKÖRPER MAGNETO-TERMICO RESISTENCIA	A	TELERUTTORE CONTACTEUR CONTACTOR SCHALTSCHÜTZ CONTACTOR	A	MAGNETOTERMICO RESISTENZA MAGNETO-TERMIQUE RÉSISTANCE TERMO-MAGNETIC SWITCH FOR HEATHER TERMO-MAGNETISCHER SCHALTER F. EIZKÖRPER MAGNETO-TERMICO RESISTENCIA	A	TELERUTTORE CONTACTEUR CONTACTOR SCHALTSCHÜTZ CONTACTOR	A
6	120469	12	121020	20	120468	9	121019	16
10	120473	40	121023	40	120470	16	121020	20
16	120474	50	121025	63	120471	26	121022	32
18	120475	63	121025	63	120473	40	121023	40
21	120475	63	121026	80	120473	40	121023	40
25	120475	63		100	120473	40	121024	50
29		75		100	120475	50	121025	63

	BOBINA DI SGANCIO V. 24 PER BOILER BOBINE DÉCROCHAGE V. 24 POUR SURCHAUFFER DISCONNECTING COIL V. 24 FOR BOILER AUSLÖSESPÜLE V. 24 FÜR BOILER BOBINA DE DESEMBRAGUE V. 24 POR BOILER		CONTATTO PER BOBINA DI SGANCIO CONTACT BOBINE DÉCROCHAGE CONTACT FOR DISCONNECTING COIL KONTAKT AUSLÖSESPÜLE CONTACTO BOBINA DE DESEMBRAGUE
630977		130925	

	KW	220/240 V				380/415 V			
		TELERUTTORE CONTACTEUR CONTACTOR SCHALTSCHÜTZ CONTACTOR	A	MAGNETOTERMICO MAGNETO-TERMIQUE TERMO-MAGNETIC TERMO-MAGNETISCHER MAGNETO-TERMICO	A	TELERUTTORE CONTACTEUR CONTACTOR SCHALTSCHÜTZ CONTACTOR	A	MAGNETOTERMICO MAGNETO-TERMIQUE TERMO-MAGNETIC TERMO-MAGNETISCHER MAGNETO-TERMICO	A
	0,12			121030	1÷1,6			121030	1÷1,6
	2,2	120469	12	121034	6,3÷9	120468	9	121033	4÷6,3
	0,11	120468	9	121027	0,25÷0,4	120468	9	121027	0,25÷0,4
	3	120470	16	121035	9÷12,5	120469	12	121034	6,3÷9
	0,55	120468	9	121032	2,5÷4	120468	9	121031	1,6÷2,5

29 - Electrical parts

CODE	DESCRIPTION
120468	CONTACTOR ABB 9A 24V 50/60HZ
120469	CONTACTOR ABB 12A 24V 50/60HZ
120470	CONTACTOR ABB 16A 24V 50/60HZ
120471	CONTACTOR ABB 26A 24V 50/60HZ
120473	CONTACTOR ABB 24V 50/60HZ
120474	CONTACTOR ABB 50A 24V 50/60HZ
120475	CONTACTOR ABB 63A 24V 50/60HZ
121019	MAGNETOT.SWITCH S253C16
121020	CIRCUIT BREAKER 20A
121022	CIRCUIT BREAKER 32A
121023	CIRCUIT BREAKER 40A
121024	CIRCUIT BREAKER 50A
121025	CIRCUIT BREAKER 63A
121026	MAGN.SWITCH 80A
121027	CIRCUIT BREAKER 0,25-0,4A
121030	CIRCUIT BREAKER 1,0-1,6A
121031	CIRCUIT BREAKER 1,6-2,5A
121032	CIRCUIT BREAKER 2,5-4,0A
121033	CIRCUIT BREAKER 4,0-6,3A
121034	CIRCUIT BREAKER 6,3-9A
121035	CIRCUIT BREAKER 9-12,5A
130925	CONTACT FOR CIRCUIT BREAKER
630977	COIL FOR CIRCUIT BREAKER 24V